



# Reference Guidebook for State-Owned Collections Care

---



**Compiled by:**

**Todd C. McMahon, Staff Archaeologist/State Curation Coordinator**

**Edited By:**

**Heather Christenbury, State Archaeologist's Collections Assistant Intern**

**Alaura Hopper, State Archaeologist's Collection Assistant Intern**

**Office of Archaeology and Historic Preservation**

**September 15, 2022**

# Table of Contents

## Guidelines and Procedures

1. State Rules and Procedures for Archaeological and Paleontological Curation.....	3
2. Submission Guidelines for State-Owned Archaeological Collections.....	10
3. Loan Agreement Guidelines.....	13
4. Guidelines for the Disposition on Non-Curated State Collections.....	17
5. Standard Requirements for Curation Agreement Templates.....	22
6. List of Official Forms.....	24

## Reference Materials

1. Repository Collections Policy Template.....	26
2. Pocket Response Plan.....	30
3. Collections Labeling and Packing Guide.....	31
4. Curatorial Care of Archaeological Objects.....	39
5. Packing Museum Objects for Museum Shipment.....	57
6. Helpful Notes on Smaller Exhibits.....	62

## Collections Management References

1. Collection Management Guide.....	64
2. Registration.....	64
3. Web Resources	
3a. Archaeological Collections Care and Management.....	65
3b. National Associations and Accreditation.....	65

# Guidebook for State-Owned Collections

---

3c. Regional Associations.....65

## **Supplies Sources**

1. Archival Boxes.....66

2. Polyethylene Bags.....66

# Guidelines and Procedures

## 1. Rules and Procedures for Archaeological and Paleontological Curation

### DEPARTMENT OF HIGHER EDUCATION

#### Historical Society

### HISTORICAL, PREHISTORICAL, AND ARCHAEOLOGICAL RESOURCES

#### 8 CCR 1504-7

#### SECTION 9. Curation of collections in approved museums

- A. The state of Colorado holds title to all historical, prehistorical and archaeological materials collected from areas owned by the state or any of its political subdivisions.
- B. While the society is the official trustee of the State of Colorado (CRS 24-80-202), the society wishes to advance a collaborative partnership with county and local museums or curatorial repositories, (a curatorial repository is a permanent, nonprofit educational or research oriented agency or institution, having professionally trained on-site staff, that provides housing and collections care in-perpetuity), to ensure long-term preservation and interpretation of these items. These institutions help to preserve, interpret and promote the natural and cultural inheritance of humanity in Colorado and work in close collaboration with the communities from which their collections originate as well as those they serve. Such an arrangement with the State is advantageous to everyone in Colorado.
- C. All materials, except human remains and associated funerary objects, collected from state lands or political subdivisions must be curated in a museum, unless a reputable museum, university, college or other recognized scientific or educational institution can assure permanent preservation on the site.
  1. Historical, archaeological, prehistorical, and paleontological collections made under permit may include ceramic, lithic, glass, metal, faunal, floral, and synthetic materials, as well as documents, photographs, organic samples (such as coprolites or soil samples), fossils (vertebrates, invertebrates, paleobotanical, ichnofossils, and associated rock or sediment samples), and human remains and associated funerary objects.
  2. Permittees proposing to transport collections out of Colorado must secure a loan agreement between an out-of-state facility and a permanent approved on-site institution, reputable in-state museum, or curatorial repository, subject to the approval of the society, except that ancillary samples may be transported and analyzed without such a loan agreement. Out-of-state analysis of human remains and associated funerary objects is subject to the approval of the society.
  3. Proposed analysis of artifacts or fossils which would cause their destruction or damage, such as trace-element analysis of materials, may be performed only with the written consent of the society through the state archaeologist, who shall consider whether such artifacts are unique or duplicated in state-owned collections. The society will supply notification of consent to the affected museum within thirty days.



# Guidebook for State-Owned Collections

---

4. State, County and local agencies or research/educational institutions wishing to ensure collections care of artifacts or specimens permanently on-site (or within close proximity to the origin of the excavated materials) must either be approved through a request to serve as an approved museum or curatorial repository as specified in Section 9 (l) of this chapter or through execution of a special held-in-trust collections agreement with the society.
- D. Reburial or repatriation of human remains may supersede their placement in an approved museum.
- E. Collections from state or political subdivision lands obtained from an issued permit in accordance with CRS 24-4-104 must be curated in an approved reputable Colorado museum or curatorial repository. The relationship between the society and another reputable Colorado museum or a curatorial repository is an express trust. Title and ownership of these collections is not transferred and the society has the authority to transfer and approve stewardship of the collections through an on-site held-in-trust collections agreement or through the approval of a reputable museum or curatorial repository as outlined in Section 9 (l) of this chapter.
- F. Collections recovered from lands owned or controlled by the state or any of its political subdivisions shall be deposited at an approved museum, curatorial repository, an approved on-site agency, or institution within six months after submission of the permittee's final report. Collections made from permitted archaeological or paleontological projects occurring over multiple years should not be deposited with different museums or curatorial repositories unless an approved museum, curatorial repository, on-site agency or institution, lacks expertise or environmental conditions necessary to ensure the collection's long-term preservation.
- G. Responsibilities and requirements of approved museums or curatorial repositories

Museums and curatorial repositories must be open to the public. They must agree to provide curation of archaeological or paleontological resources in a systematic and accessible manner, and to make them available free of charge for study by qualified students and researchers.

1. Provide a copy and maintain a current and active fine art or other commercial insurance policy or if the museum or curatorial repository whose collections are primarily owned or overseen by a governmental entity, acknowledge that the state collection and any associated state property are covered for liability from any loss or damage.
2. If accepting collections from outside researchers, institutions issuing curation or similarly worded "intent-to-curate" agreements to third-party permitted researchers must first have their template agreement language approved by the state archaeologist or his/her staff designee to avoid confusion that the collections have state of Colorado title.
3. Within ten working days refer to the state archaeologist of Colorado all requests (written and oral) for transfer or repatriation of the state collection (or any part thereof).
4. Maintain separately all written and digital descriptive information associated with the curated state collection, including field notes, site forms and reports in a safe and secure manner.
5. Do not release to any third-party any precise information relating to the exact physical location of a prehistoric site (locale) from which the state collection (or any part thereof) derives, except to qualified researchers or after obtaining from the state archaeologist of Colorado prior written permission. If there are questions as to releasing this information, approved museums or curatorial repositories will consult with the state archaeologist of Colorado.
6. In accordance with these regulations, be open and subject to inspection by the state archaeologist or his/her designee at least once every three years.

# Guidebook for State-Owned Collections

---

7. Accept state collections from permitted work for their specific regional or local area guided by these current rules and procedures and the approved museum's or curatorial repository's collection management policy.
8. Annually report back to the state archaeologist or his/her designee any changes to the state's collection condition or insurance policy changes, loan agreement status and any other tracking requirement methods adopted by the society and the office of the state archaeologist.
9. Properly maintain any State of Colorado property (shelving, cabinetry etc.) in its possession associated with the care of the state collection.
10. Maintain the collection within inert and acid-free storage or packaging.
11. With the exception of approved repatriation, not sell, transfer, assign, pledge, encumber, discard, or otherwise dispose of the state collection (or any part thereof) or any associated State of Colorado property in its possession without written and signed permission from the state archaeologist.
12. Have an established collections management policy and emergency management plan.
13. Within five calendar days of the discovery of any loss or theft of, deterioration or damage to, destruction of the state collection (or any part thereof), or any State of Colorado items of property used to support and care for a state collection in the museum's or curatorial repository's possession, the museum or repository will provide to the society written notification of the circumstances surrounding the loss, theft, deterioration, damage, or destruction, and will report to the state archaeologist or his/her designee those actions taken to stabilize the collection, or State of Colorado items or property, and to correct any deficiencies in the physical plant or operating procedures that may have contributed to the loss, theft, deterioration, damage, or destruction.
14. Other than routine, small and simple paleontological specimen or artifact mending repairs, any planned actions that involve major repair or restoration beyond basic re-attachment of the state collection (or any part thereof) or any other State of Colorado property associated with the state collection must be approved of in advance after consultation with the state archaeologist.
15. The society (in co-ordination with other reputable museums, nonprofit or governmental educational institutions) reserves the right to take custody of state collections in the care of an approved museum, curatorial repository, on-site agency or institution through a loan agreement for temporary exhibit purposes.

## H. Approved Uses

1. Approved museums or curatorial repositories and the society may fully exhibit and charge reasonable nondiscriminatory admission fees, comparable to fees charged at similar facilities to view these items prepared for interpretive display (either for permanent, temporary or travelling exhibition purposes). Additionally, approved museums or curatorial repositories and the society may photograph and nondestructively study the state collection (or any part thereof) on the museum or curatorial repository's premises, subject to the museum or repository's own collections management policies and in accordance with these regulations. Physical reproduction of any state collection item(s) must be approved of in advance by the state archaeologist.

# Guidebook for State-Owned Collections

---

2. State paleontological resources curated at an approved museum or curatorial repository may be cleaned, treated, stabilized and prepared for research, exhibition or loan transportation purposes under standard professional best practices for natural history collections.
3. A held-in-trust state collection may be loaned out by an approved museum or curatorial repository to other institutions and organizations (including for temporary exhibition or study by the society) by securing a loan agreement between the other facilities provided notice of the arrangement is sent to the state archaeologist for tracking purposes. The director of the approved museum or curatorial repository is responsible for all loan transactions of state collections and for ensuring that appropriate and timely administration of the loans is conducted. Relocation inventories must be conducted and included as part of the written loan agreement. Other loan conditions must be addressed in the Collections Management Policy of the curatorial facility that is loaning the material. The loan and transportation of the state collection must be insured for liability purposes through securing a commercial fine art or other insurance policy or be adequately covered by governmental self insurance to fulfill any damage or loss incident. Collections that are not inventoried or cataloged shall not be loaned. Commercial use of loaned collections is prohibited without written consent from the society. Ancillary samples may be transported and analyzed without a formal loan agreement; however, the museum or curatorial repository will provide to the society two copies of any publications, reports, and other documents prepared by researchers studying ancillary samples.
4. All exhibits, reproductions, and studies will credit the state archaeologist of Colorado as follows: “Courtesy of History Colorado, Office of the State Archaeologist.” The museum or curatorial repository will provide to the society two copies of any publications, reports, and other documents prepared by museum or curatorial repository staff studying or exhibiting the state collection (or any part thereof).
5. Approved museums or curatorial repositories and the society may charge a competitive deposit fee for the collections and reasonable administrative processing fees for “curation” or similarly worded “intent-to-curate” agreements with permittees. Permitted researchers that deliver collections not according to the state archaeologist’s current Submission Guidelines for State-Owned Archaeological Collections and these regulations may be subject to corrective hourly labor rate fees plus the cost of supplies by the state approved museum or curatorial repository.

## I. Procedures for approving museums

1. Any institution wishing to serve as a museum for collections from state lands (or any subdivision of state lands) or collected as a result of work carried out under a permit issued under authority of this Act shall apply to the society through the state archaeologist for approval.
2. The museum or curatorial repository shall fill out a *Request to Serve as an Approved Museum or Curatorial Repository for Held-in-Trust Collections* form, signed by the director of the institution and must evidence reputable status with any of the following credentials (or their equivalent successor museum program/designations):
  - a. Received from the American Association for State and Local History (AASLH) silver or gold certificates by participating in the Standards and Excellence Program for History Organizations (*StEPs*) in the stewardship of collections section within the last five years.

## Guidebook for State-Owned Collections

---

- b. Show evidence of participation in the Museum Assessment Program in the area of collections stewardship from the American Alliance of Museums within the last five years.
    - c. Received Core Documents Verification from the American Alliance of Museums within the last five years.
    - d. Received and maintain formal Accreditation status from the American Alliance of Museums.
    - e. Considered a designated Federal Repository for curating federally-owned and administered archaeological or paleontological collections under the requirements of Federal Regulations 36 CFR 79.
  3. Provide proof to the state archaeologist of a fine art or other appropriate umbrella insurance policy that will adequately cover the care for the state collection from any one claim or aggregate claim arising from a damage or a loss incident. With the insurance policy documents, the society and the approved museum or curatorial repository should be shown as co-beneficiaries (or additionally insured).
    - a. If the museum or curatorial repository's collections are primarily owned or overseen by a Colorado governmental entity (considered a "public entity" within the meaning of the Colorado Governmental Immunity Act, CRS 24-10-101, et seq.), the museum or curatorial repository must indicate to the state archaeologist that they are self insured in lieu of the fine art or other umbrella insurance policy requirement stated above. If self insured, it is understood that the public entity of the approved museum or curatorial repository will ensure liability to the state collections under its care arising from a damage or a loss incident.
    - b. In the event of a loss incident, a liability assessment of the value of the collection shall be determined by mutual agreement with the society as the sum of the estimated current fair market value and the estimated costs of replacing the scientific and educational information from the lost artifacts or specimen. A determination of these replacement costs may include, but are not limited to: (a) research design development; (b) fieldwork; (c) laboratory analysis; (d) curation; (e) reports or educational materials; and (f) lost visitor services or experience. In some cases, it may be appropriate for the estimated cost of replacement value to be peer reviewed by archaeologists or paleontologists with appropriate expertise and with no conflicts of interest.
4. If the museum or the curatorial repository curates collections from permitted researchers outside of their approved institution, provide a template copy of a "curation" or similarly worded "intent-to-curate" agreement for approval by the state archaeologist or his/her designee. The agreement form must clearly acknowledge that title to the artifacts or specimens as well as all associated reports, original field notes, maps, drawings, photographs etc., resulting from the investigations to be curated remains solely with the State of Colorado.
5. Approval of a museum or a curatorial repository shall be effective for a period of five years, after which time, the curatorial facility may apply for renewal through the procedures in this chapter.
6. The completed documentation shall be reviewed by the state archaeologist or his/her designee within 30 days of receipt. If clarification or additional information is requested by the society, the facility shall have 30 days to furnish the information required.

# Guidebook for State-Owned Collections

---

7. The museum or curatorial repository may discontinue accepting new collections from outside researchers by amending their agreement upon renewal to serve as an approved facility. Once approval of a museum or a curatorial repository has been granted however, the express trust arrangement with the State of Colorado continues and is perpetual for any of the existing collections under the institution's stewardship.
8. The society has sole discretion to approve or not approve a museum's or curatorial repository's application.
9. Approval may be withdrawn by the society through the state archaeologist if deficiencies in collections care and non-compliance to these regulations appear. Approval will be suspended or revoked in accordance with CRS 24-4-104.
10. Under the authority of CRS 24-80-407, the society may exercise the right to enter into agreement with museums, curatorial repositories, or other public or private entities to fulfill the State's needs for held-in-trust state collections concordant to these rules and regulations.
11. For each deposited historical, prehistorical, archaeological or paleontological state collection, the approved museum or curatorial repository will sign and acknowledge an official deposit receipt form with a simple inventory list of items accepted for permanent curation by the facility, a copy of which will be forwarded to the state archaeologist or his/her designee.

## J. Continuance of pre-approved museums and repositories

1. Previously approved non-expiring museums and curatorial repositories shall honor existing "intent to curate" or similarly worded executed curation agreements with third-party researchers (permittees) up to five years after the effective date of these revised rules unless individual contractual agreements expire within five years. Notice from an approved museum or curatorial repository for continuing the acceptance of collections from previously dated permittee agreements must be given to the state archaeologist of Colorado or his/her designee within 30 days after the expiration date for renewal of approved status. The notice shall be made through the *Request to Serve as an Approved Museum or Curatorial Repository for Held-in-Trust Collections* form and the museum or repository must list the number and names of all outstanding agreements along with their expiration dates. Extended approval of these previously approved museums or curatorial repositories shall then be made for a period of up to five years based on furthest dated agreement and shall not extend beyond five years following the effective date of these adopted and revised rules.
2. Museums or curatorial repositories that hold in custody held-in-trust state collections that were collected as a result of CRS 24-04-104 that decide not to become a newly approved museum or curatorial repository under these revised rules should nonetheless attempt to provide the highest possible level of care to the existing state collections currently maintained in their facilities. At a minimum, a level of care that prevents deterioration of, damage to or loss of items in the state collection should be maintained.
3. Within five years of the effective date of the adoption of these revised rules, previously approved non-renewing museums or curatorial repositories should either submit a plan for the state archaeologist of Colorado's approval regarding the continued care and management of the state collection or plan for the transfer of the state collections to a museum or curatorial repository approved under the revised 8CCR 1504-7 Section 9 (I) of this chapter.

## Guidebook for State-Owned Collections

---

### K. Responsibilities of permittee submitting collection

1. In choosing a museum, permittees should attempt to keep the collection in its area of origin and to keep materials from the same site and the same project together. Permittees should confer with staff of the selected museum and have a written agreement whose template language was approved by the state archaeologist or his/her designee as specified in Section I (4) of this chapter prior to collecting materials in the field.
2. Permittees should follow the guidance of museum staff in regard to collecting procedures. The permittee should adhere to any specific methods of labeling, packaging, and shipment required by the museum and the state archaeologist's current Submission Guidelines for State-Owned Archaeological Collections. All collections must be placed and delivered within inert and acid-free packaging.
3. The permittee is responsible for returning to the office of the state archaeologist a fully signed official state deposit receipt form by the approved museum, curatorial repository, on-site agency, or institution and the office of the state archaeologist of Colorado. The form must be accompanied by a simple inventory list of items accepted by the approved facility for permanent curation.

## Guidelines and Procedures

### 2. Submission Guidelines for State-Owned Archaeological Collections

#### Submission Guidelines for State-Owned Archaeological Collections

(Revised July 13, 2022)

These guidelines are offered by the Office of the State Archaeologist (OSAC) to strengthen the statewide curation network. They list standard best practices for collections submitted to Colorado repositories under the authority of a State permit. While these guidelines apply to archaeological materials, they may also broadly apply to paleontological collections as well. Please be aware that individual State repositories may have more stringent requirements that will supersede those listed below.

#### Organization and Container Storage Standards

All archaeological and paleontological collections submitted must reference the official State of Colorado Smithsonian Trinomial Site Number. It is also assumed—with rare exceptions—that material collections to be housed have already been analyzed, and therefore artifact cleaning or fossil preparation, conservation, and inventorying have been completed. While specific guidelines are formulated by each repository, at a minimum each depositor should ensure the following common best practices.

1. Material collections must be accompanied by all documenting records (held-in-trust collection inventory form or substitute inventory “catalog”, a copy of the official receipt for deposit form, field notes, site forms, photos, maps, reports, formal deeds of gift, and other contracts or agreements preferably printed on acid-free archival paper). Photographic records (i.e., slides, negatives, prints) should be enclosed in acid-free polyethylene holders or sleeves. An explanation of the indexing method used to organize the boxed materials should also be provided. In addition to the secure hardcopies, documentation in digital format may also be submitted to the repository if they have the means to store these data, as well as an established policy for secure data archiving and migration. If the facility lacks these means then all the miscellaneous digital (non-required reporting) data should be submitted to OSAC.
2. All materials should be cleaned and preserved using appropriate reversible, nondestructive techniques. Documentation should include a record of any applied techniques performed on any artifact or fossil. Justification and repository approval should be provided for retaining any soil matrix adhering to any artifact for future analysis.
3. Specimens needing ongoing conservation should be separated and documented. Exceptional specimens should be noted. If ongoing conservation needs are anticipated, a plan should be drafted to address their long term conservation requirements.
4. All specimens or collections should be labeled or bar-coded individually in accordance with the cataloguing, and labeling systems of the repository. Since the State holds title interest in the items being deposited, our office should be consulted to determine labeling standards if the repository has not adopted formal standards for cataloguing and labeling.
5. Typically specimens should be individually labeled (with a reversible base coat and indelible stamp, India ink, bar-coded, etc.) with a site designation and field provenience. If specimens are too small to be numbered individually and/or for large groups of similar specimens are from the same provenience, then they may be put together in labeled, appropriately sized acid-free containers.



# Guidebook for State-Owned Collections

---

6. Acid-free fabric or acid-free paper tags should be appropriately affixed to perishable or fragile specimens that are not to be directly marked upon.
7. All artifact bagging must be done with archival quality plastic, rather than paper bags.
8. All boxed containers housing bagged materials must be stable and sturdy, in acid-free boxes and should fit the size/shape requirements of the collection. In our experience storage boxes are typically no larger than one cubic foot, but there will necessarily be exceptions.
9. Larger containers, such as acid-free storage boxes, should be labeled with permanent markers/ India ink or appropriately affixed printed labels on their exterior surfaces. Labels in or on containers should provide the following information: site designation, project name and date, provenience data, analytical group, and number of artifacts or specimen.
10. Following any artifact study, analytical categories (flaked lithic materials, groundstone, etc.) should be maintained but not disassembled from field provenience organization for housing the collection. For instance obsidian samples removed for specialized sourcing must be returned to their field provenience bag after the analysis has been completed.
11. A held-in-trust collection inventory list should accompany each collection. This inventory or “catalog” must accurately reflect the quantity of the material and the analysis and packaging order. Analytical group designations on inventories should correspond to those used in the final report and on packaging labels. This list should also be made available in an electronic format (such as a standard MS Excel spreadsheet) that is provided to both the repository and OSAC as part of an issued State Permit’s annual and final reporting requirements. Artifact/specimen quantities for annual and final reports should corroborate. Please refer to our office’s official receipt for deposit form and its attached inventory sheet example for minimum reporting categories.
12. The quantity of bulk samples (e.g., matrix, soil, burned rock) or redundant non-diagnostic materials to be curated should be discussed and agreed to by the repository prior to any acceptance (please see *The Guidelines for the Disposition of Non-Curated State Collections From a Research Lab or a Museum/Repository* for further guidance). The determination of acceptance should give comprehensive consideration to the potential of artifacts or specimens for future research and to the limited space for housing in most repositories.

## Ownership Documentation

Private collections deposited at a State-Approved repository must be accompanied by a signed Deed of Gift or a similar document from the private landowner. The signed and dated document must indicate the owner’s name, legal address, other contact information, and indicate that the collection being donated is unrestricted and irrevocable. Note that private landowners or entities must negotiate directly with each repository for these agreements unless either through contract or assignment a consultant assumes the role of legal agent for the private owner. If the repository is a part of a subdivision of State government (City, County, local, district) and private ownership of that item(s) has been transferred to a non-Federal government entity then the State holds a title interest in that specimen/artifact. Unless requested by the State-Approved repository, permitted researchers collecting from non-Federal public lands do not need to provide ownership documentation. However it is the responsibility of the permitted researcher depositing collections to ensure the repository of the accurate ownership status of all specimens or artifacts deposited for curation.

(These guidelines will be subject to review by OSAC at least every five years)



## Guidelines and Procedures

### 3. Loan Agreement Guidelines

#### Outgoing Loan Agreement Guidelines for Held-In-Trust Collections

History Colorado encourages exhibition of held-in-trust archaeology and fossil collections through proper execution of museum/repository loan agreements. Pursuant to History Colorado's and the State-Approved Museums and Curatorial Repositories program rules and policies (8 CCR 1504-7, Section 9); this guidance is intended to aid institutions with outgoing loan best practices.

#### Basic Pre-Requirements

**Length of Loans.** All loans should typically be made for three (3) years or less. Loans of greater length pose a risk of loss of control of the collection. A best practice actually is to grant only one (1) year loan agreements that may be renewed upon review and re-approval not to exceed a three-year continuous period. This arrangement allows for a yearly check on the status of the loan and greater assessment on the condition of the artifacts/fossils by the lending institution.

**Entities that May Borrow.** With rare exceptions, State collections should not be loaned to individuals. However, institutions may loan materials from one research institution/museum or repository to another, thereby providing researchers access to the materials at the nearest museum or repository. Many repositories also allow for the loan of microfilm, photocopies, or facsimiles, as opposed to original records.

#### State Requirements of Outgoing Loan Agreements

**Notice Requirement.** As stated in the State-Approved Museums and Curatorial Repository rules and procedures (8 CCR 1504-7, Section 9), held-in-trust state collection may be loaned out to other institutions and organizations by securing a loan agreement between the other facilities provided **notice** of the arrangement is **sent** to the State Archaeologist (c/o the State Curation Coordinator) for tracking purposes. Notices must include at a minimum: the artifact(s)/fossil(s) description, catalog number(s), the Colorado Smithsonian site number(s) from which the artifact(s)/fossil(s) are derived, the full borrowing institution's contact information (i.e. name, contact, address, phone, e-mail), the type of loan (e.g. exhibit, conservation, fossil prep, research etc.) and the duration of the loan.

**When is Permission from the State Archaeologist Required?** Permission is required if a loan is proposed and initiated by a researcher for out-of-state study or for any destructive analysis (beyond fossil preparation or destruction of ancillary samples) (see page 5 for more information on requesting permission). If the loan is initiated by a State-Approved Museum/Repository for exhibition, conservation, in-state study or fossil preparation purposes prior approval from the State Archaeologist is not required however all loans must be reported by giving notice to the State Archaeologist (c/o the State Curation Coordinator) as described above.

**Responsible Party.** The director of the approved museum or curatorial repository is responsible for all loan transactions of state collections and for ensuring that appropriate and timely administration of the loans is conducted.

**Loan Inventories are Required.** Relocation inventories must be conducted and included as part of the written loan agreement.

# Guidebook for State-Owned Collections

---

**Insurance is Required.** The loan and transportation of the state collection must be insured for liability purposes through securing a commercial fine art or other insurance policy or be adequately covered by governmental self-insurance to fulfill any damage or loss incident. Collections that are not inventoried or cataloged shall not be loaned.

All loaned objects must be covered by insurance in the full amount of the value (fair market plus estimated replacement value) specified by State-Approved repository from the time the objects are removed from the repository until they are returned in satisfactory condition. Coverage afforded must be “all risk,” “wall to wall” (“nail to nail”). As proof that the loaned objects under the borrower’s policy meet this specification a certificate of insurance, indicating that the State-Approved Museum/Repository and History Colorado (State of Colorado) are shown as additional insured under the policy should be forwarded to the lending State-Approved Museum/Repository prior to the shipping date.

The loaning museum/repository as well as the borrower must understand that in the event of a total collection loss, a liability assessment of the value of the collection shall be determined by mutual agreement with History Colorado as the sum of the estimated current fair market value and the estimated costs of replacing the scientific and educational information from the lost artifacts or specimen. A determination of these replacement costs may include, but are not limited to: (a) research design development; (b) fieldwork; (c) laboratory analysis; (d) curation; (e) reports or educational materials; and (f) lost visitor services or experience. In some cases, it may be appropriate for the estimated cost of replacement value to be peer reviewed by archaeologists or paleontologists with appropriate expertise and with no conflicts of interest.

**Commercial Use is Prohibited.** Commercial use of a State collection is prohibited without written consent from History Colorado.

**Ancillary Samples Do Not Require a Loan Agreement.** Ancillary samples defined as organic or inorganic specimens, other than human remains or artifacts, gathered by scientists for the purpose of analysis to provide information on past environments, diets, chronology, or material source areas. Ancillary samples may include, but are not limited to, charcoal, wood, soil, coprolites, and floral or faunal specimens. Such objects may be transported and analyzed without a formal loan agreement; however, the museum or curatorial repository will provide to History Colorado two copies of any publications, reports, and other documents prepared by researchers studying ancillary samples.

**Credit Line.** All exhibits, reproductions, and studies will credit the State Archaeologist of Colorado as follows: “Courtesy of History Colorado, Office of the State Archaeologist.” The museum or curatorial repository will also provide to History Colorado two copies of any publications, reports, and other documents prepared by museum or curatorial repository staff studying or exhibiting the state collection (or any part thereof).

**Damages.** Damages, whether in transit or on the borrower’s premises, and regardless of responsibility, shall be reported immediately to the outgoing State-Approved repository that is loaning such objects. Within five calendar days of the discovery of any loss or theft of, deterioration or damage to, destruction of the state collection (or any part thereof), or any State property used to support and care for a state collection, the lending State-Approved museum/repository will provide to the Office of the State Archaeologist’s State Curation Coordinator written notification of the circumstances surrounding the loss, theft, deterioration, damage, or destruction, and actions taken to stabilize it. This includes any supporting state property (shelving/cabinets etc.) and efforts to correct any deficiencies in the operating procedures or environment that may have contributed to the loss, theft, deterioration, damage, or destruction.

**Condition of the Collection.** Borrowers should agree to maintain the loaned objects in the condition in which they are received and not to permit cleaning, repairing, retouching, or alteration of any kind without the outgoing loaned repositories prior written consent. Other than routine, small and simple paleontological specimen or artifact mending repairs, any planned actions that involve major repair or restoration beyond basic re-attachment of the state collection (or any part thereof) or any other State of Colorado property associated with the state collection must be approved of in advance after consultation

# Guidebook for State-Owned Collections

---

with the State Archaeologist. The agreement should describe the condition of the item when it was loaned, noting any blemishes for which the recipient should not be held accountable and providing the lender with a means to demonstrate the condition of the item when it left their care in case it is returned damaged. Some institutions may ask for a special condition report to be filled out and returned by the borrower.

**Title and Rights.** Loan agreements do not confer on the borrower any right, title, or interest in a held-in-trust State collection. All State-owned objects remain the sole and exclusive title of the State of Colorado. The borrower should also agree to return such objects immediately upon demand by the State-Approved Museum/Repository or if the lending repository is in breach of a loan contract/agreement as History Colorado may direct.

## Other Common Standard Terms and Conditions

**Stable Condition.** Loans should only be made if the subject object(s) are in stable condition and appropriate for the purpose of a loan (except when loaned for repair).

**International Loans.** Foreign, out of country loans must address all packing, shipping, insurance, destination, and customs information. Loans out of the country can be complicated due to language barriers, customs and government rules. It is best to seek the advice of legal counsel when dealing with international loan requests.

**Exposures.** Borrowers should not expose loaned objects to damage from unfiltered ultraviolet radiation, biological agents, or unstable environmental conditions.

**Transportation Costs.** Borrowers should agree to pay all costs involved in the transportation of loaned objects, including framing, matting, packing, crating, shipping, and for the hiring of special packers when such hiring is deemed necessary.

**Lender's Contact Information.** Lender's name and full contact information. This will enable the recipient to easily contact the lender if a question arises about the loan or the item.

**Borrower's Contact Information.** Recipient's name and full contact information. This will enable the lender to easily contact the recipient if a question arises about the loan or the item.

**Loan Purpose.** The agreement should describe why the item(s) are being loaned and how it will be used. For example, is the item to be used in an exhibit that will be open to the public? Is the item to be displayed at a private fundraising reception? Is the item to be used by the recipient's staff for research purposes? Is the item being provided to a vendor or other institution to be scanned?

**Description of the Artifacts/Fossils.** The agreement should carefully describe the item so that it can be readily identified. Please use the official site number (e.g. 5AM2), site name and artifact/fossil description (e.g. three pound two-handed red sandstone mano with small hatch indent on the largest flat surface).

**Storage and Exhibition Requirements.** Some repositories will include information on how the item must be stored and/or exhibited.

**Signature, Title, and Date.** Representatives of the lender and borrower, who are authorized to enter into a legally binding document (e.g. the historical society president or director of a museum), should sign and date the loan agreement.

**Acknowledgement of Return.** The loan agreement should include an area to be completed upon the item's return in which a representative of the lender acknowledges that the item was received and notes the condition upon return.

# Guidebook for State-Owned Collections

---

**Security.** Regardless of the type of loan, certain security procedures should be in place to protect the artifacts/fossils. Evidence of security procedures must be present before a loan agreement is signed. At a minimum, it is best practice to maintain loaned objects securely within a 24-hour-a-day security alarm system.

**Legal Note.** Only one document can govern any loan transaction. Multiple loan agreements for the same action cannot be enforced. The last one signed will invalidate earlier signed forms. If the museum has specific concerns or specific requirements not addressed on the borrower's agreement, the lender should amend the loan agreement provided by the borrower as needed rather than issuing another outgoing loan agreement.

Outgoing loan agreements are contracts and should be vetted by your legal counsel.

## For Researchers and Permit Holders

**Out of State Analysis or Study.** Permittees and researchers proposing to transport collections out of the state of Colorado must secure a loan agreement between an out-of-state facility and a permanent approved on-site institution, reputable in-state museum, or curatorial repository, *subject to the approval of History Colorado (via the State Archaeologist)*. Ancillary samples however may be transported and analyzed without such a loan agreement or prior approval from History Colorado. Any proposed out-of-state analysis of human remains and associated funerary objects is subject to the approval of History Colorado.

To request permission to transport State artifacts/fossils out of state please fill out and return Form #1656, *the Request for Non-Destructive Out-of-State Transportation Approval for Held-In-Trust Artifacts or Fossil Specimen* found on-line.

**Destructive Analysis Request.** Proposed analysis of artifacts or fossils, which would cause their destruction or damage, such as trace-element analysis of materials, may be performed *only with the written consent of History Colorado through the State Archaeologist*, who shall consider whether such artifacts are unique or duplicated in state-owned collections. If part of the artifact/fossil will remain intact after the analysis is completed and will be returned to the repository for continued curation, an outgoing loan agreement must be issued for the artifact(s)/fossil(s). The Office of the State Archaeologist will supply notification of consent to the affected museum within thirty days, after filling out and sending back to the Office with the proper request form.

To request permission to perform destructive analysis on State artifacts/fossils please fill out and return Form #1647, *Request for Destructive Analysis Approval of Held-In-Trust Artifacts or Fossil Specimen* found on-line.

# Guidebook for State-Owned Collections

## Sample Loan Agreement Form

### OUTGOING LOAN AGREEMENT

LOAN NUMBER \_\_\_\_\_

This agreement is between (REPOSITORY NAME) and the borrower whose name appears below (herein called the Borrower), and provides for the loaning of the object(s) described below, for the purpose of exhibition or study and subject to all terms and conditions of this agreement.

Loan Period:	DATE to DATE
Borrower:	NAME OF INSTITUTION
	CONTACT NAME
	TITLE
	ADDRESS
	CITY, STATE, ZIP
Office phone:	XXX-XXX-XXXX
Email:	
Description:	
<b>Object ID</b>	<b>Object Information</b>
	<b>Current Value:</b>
	<b>Total loan Value:</b>
	<b>\$0.00</b>
Shipping Instructions:	

**Notes:**

INSURANCE COVERAGE TO BE ASSUMED BY:  BORROWER

Signature below signifies acceptance of all Terms and Conditions of this agreement.

Borrower \_\_\_\_\_ Date \_\_\_\_\_

Printed Name/Title \_\_\_\_\_

Repository Name \_\_\_\_\_ Date \_\_\_\_\_

Printed Name/Title \_\_\_\_\_

Borrower Initials: \_\_\_\_\_

**Terms and Conditions for Outgoing Loans**

Loans of study, exhibition, analysis, repair, or appraisal, and are made only to other historical agencies or educational and cultural institutions (except for the purpose of repair, analysis, or appraisal). Loan of an object is made only if Repository considers the loan to be in the best interest of the collection. Loans are not made of extremely fragile materials, including society exhibits.

The shipping date in order to allow time for photography, packing, and other arrangements.

Written in advance, in writing, all packing, shipping, insurance, destination, and customs information. In the case of foreign loans, the borrower will be in charge of coordinating the foreign loan on the borrower's behalf, and who will handle all

rights, or interest in the objects described herein except such rights as are expressly set forth herein and the borrower's responsibility, or within such period as Repository may direct.

Under the condition in which they are loaned and not to permit cleaning, repairing, retouching, or alteration of any kind without the prior written consent of Repository, and not to expose the objects to damage from environmental conditions.

For loaned objects, including framing, matting, packing, crating, shipping, and for the hiring of special packers when such authorized by Repository, objects shall be returned in the original crate for the return to Repository by the same power. Damages, whether in transit or on the borrower's premises, and regardless of responsibility, shall be covered

by the amount of the value specified by Repository, from the time the objects are removed from Repository until they are returned to Repository, or "wall to wall" ("tail to tail"). By marking the appropriate blank on the first page of this agreement, the borrower agrees

to the borrower's policy which must meet the specifications set forth above in this paragraph, in which case a copy of that Repository and History Colorado (State of Colorado) is an additional insured under the policy, must be provided to Repository.

Each year, the borrower shall review their condition and report to Repository any disagreements with the condition report for all loaned objects in the condition in which they are loaned.

From the time they are received until they are shipped back to Repository, the loaned objects will not leave the custody of the borrower and

the borrower shall be reasonably necessary to protect them against loss, breakage, deterioration, or other damage; such care to include at least (1) locked cases or in frames using glass or ultraviolet filtering Plexiglas and acid-free matting and (2) behind glass must have sufficient distance from the public to prevent touching. Exhibit areas must be under glass and open to the public.

Damage by the use of (1) ultraviolet filters on fluorescent and incandescent lights, or (2) ultraviolet filtering Plexiglas in display cases (or at least the ballast) is outside the enclosed area.

Requests by the borrower without Repository's prior permission in the form of a Repository work order form. Requests by the borrower to the object.

Request for 24-hour-a-day alarm security guard systems, or in any other security system, which shall be provided by

set forth on the first page of this agreement. Loaned objects shall be returned to Repository at the end of the loan period or to the expiration of the loan period. However, Repository reserves the right to require the early return of loaned

objects stating that they are on loan from the Repository. If requested by Repository, labels will also include the name of the donor

in any publication or catalogue regarding an exhibit involving objects loaned by Repository.

Under the terms or conditions of which the borrower is loaned by Repository in writing. Repository may impose such additional conditions on the loaned objects covered by this agreement.

Under the agreement of the borrowers, the terms of this agreement shall be controlling.

Borrower Initials: \_\_\_\_\_

# Guidelines and Procedures

## 4. Guidelines for the Disposition on Non-Curated State Collections

### Guidelines for the Disposition of Non-Curated State Collections From a Research Lab or a Museum/Repository

These guidelines establish procedures and administrative record requirements for the transfer or disposal only of select artifacts/fossils determined to be of insufficient archeological/paleontological interest and therefore “not curatable”. The guidelines are derived from amendments to 36 CFR 79 (2022) as adapted from the Federal collection disposition process. The artifacts/fossils that are the subject of these guidelines are managed at held in trust approved repositories or held temporarily by a research organization for the purposes of analysis and report writing. The procedures do not apply to entire collections, nor do they affect any material remains defined as “cultural items” or human remains by the Native American Graves Protection and Repatriation Act (NAGPRA; 25 U.S.C. 3001 et seq.) and subject to that statute. NAGPRA cultural items include Native American human remains, funerary objects, sacred objects, or objects of cultural patrimony

#### Avoid Disposition of Non-Curatable Items with Proper Planning

##### Agree to a Collection’s Strategy First

The permitted archaeologist/paleontologist should agree to a collection strategy initially before any testing or field collections are conducted. The permitted researcher or firm should have a contract or written agreement with the approved repository and agree to what will be collected and curated. All parties must make sure the repository can accommodate the anticipated needs. Some institutions may not have the ability to curate certain types of material so make sure this is understood and negotiated first. Other options may need to be explored. Strategies will be guided by the project’s research design, the scope of the project and the scale of the resource.

Collection Key Terms
<p><b>Ancillary samples</b> are defined as organic or inorganic specimens, other than human remains or artifacts, gathered for the purpose of analysis to provide information on past environments, diets, chronology, or material source areas. Ancillary samples may include, but are not limited to, charcoal, wood, soil, coprolites, and floral or faunal specimens. Such objects may be transported and analyzed without a formal loan agreement with the State-Approved repository, however, the museum or curatorial repository will provide to History Colorado two copies of any publications, reports, and other documents prepared by researchers studying the ancillary samples.</p>
<p>An <b>artifact</b> is a portable object made and/or used by humans in the past.</p>
<p><b>Diagnostic artifacts</b> are artifacts that possess characteristics of a specific time period and/or culture. Artifacts that are <b>non-diagnostic</b> lack these characteristics.</p>
<p><b>Fossil</b> means the remains or traces of an organism or assemblage of organisms preserved by natural processes in or on the earth's crust, exclusive of organisms that have been buried in recent times.</p>
<p><b>Paleontological resources</b> means fossils and other remains of prehistoric animals, plants, insects, and other objects of natural history within Colorado that do not show evidence of human association.</p>



# Guidebook for State-Owned Collections

**Prehistoric** means before the period that written records were used to document events in Colorado.

**Principal Investigator** is defined as the permitted person qualified to lead a research investigation as defined in State rules 8 CCR 1504-7 (D1 or E1) or by accepted waiver to those qualifications.

As specified under the Act's rules and procedure (8 CCR 1504-7, Sec. 9(C) 2), ancillary samples (e.g. charcoal, wood, soil, coprolites, and small floral or small faunal specimens) once analyzed may be disposed of appropriately however it may be advisable to retain a small sample of non-analyzed ancillary materials for future study following the rationale and procedure described in section 2 iii below.

## Who May Propose the Disposal of Artifacts/Fossils?

Current State-Approved repositories professionally trained staff (conservators, curators, directors, collection managers) and the Principal Investigators (P.I) from current permitted organizations or individuals with verifiable knowledge, working under the oversight of a Principal Investigator (P.I.).

## Who is Responsible for the Disposal of Artifacts/Fossils?

The State-Approved director or top management official is responsible for ensuring that particular artifacts/fossil are properly disposed of according to these guidelines.

## When are Particular Material Remains Considered to be Non-Curatable?

Particular material remains are considered to be of insufficient interest and "non-curatable" when, on a case-by-case basis by at least one qualified permitted archeologist/paleontologist (P.I.) and one museum/repository official with experience in the type of material remains being evaluated and documented demonstrates that:

(1) Disposition of the non-diagnostic material remains or fossils will not negatively impact the overall integrity of the original collection recovered during the survey, excavation, or other study of a paleontological, prehistoric or historic resource; and

(2) At least one of the following three requirements—lack of provenience information; lack of physical integrity; or overly redundant and not useful for research—are met:

(i) Lack of provenience (locational information on where the artifacts/fossils were found). Lack of provenience information may be established by one or more of the following circumstances:

(A) The labels on the artifacts/fossils or the labels on the containers that hold the artifacts/fossils do not provide adequate information to reliably establish meaningful archeological/paleontological context for the artifacts/fossils;

(B) The labels on the artifacts/fossils or the labels on the containers that hold the artifacts/fossils have been lost or destroyed over time and cannot be reconstructed through the associated records; or

(C) The associated records of the artifacts/fossils have been lost or destroyed and cannot be recovered after a concerted effort to find them is performed and documented.

(ii) Lack of physical integrity. Artifacts/fossils lack physical integrity when, subsequent to recovery during the survey, excavation, or other study of a paleontological, prehistoric or historic resource,

# Guidebook for State-Owned Collections

---

the artifacts/fossils were irreparably damaged through decay or decomposition over time, or as a result of a human-caused incident or a natural disaster.

(iii) Overly redundant and not useful for research. Disposition using this criteria must be carefully considered. It is defined as duplicated artifacts or fossils in such high quantities that the number of artifacts or fossils considered for disposition would not harm the intellectual knowledge lost by retaining a smaller representative sample of the whole population or larger set.

**Please note: A determination that artifacts/fossils are overly redundant, non-diagnostic and not useful for research must be carefully considered. Archeological/Paleontological context, research questions, and research potential may vary based on geography, geology, cultural period, scientific or cultural significance, prior analysis, and other factors. It is often difficult to predict if future analytical methods will yield useful information about the material remains proposed for disposal or transfer. As such, a representative sample of the artifacts/fossils useful for future research should be retained for curation.**

The artifacts or fossils are then either approved or denied for disposal or transfer by the State Historical Society of Colorado's (i.e. History Colorado's) President and Board of Directors acting through the State Archaeologist.

## Bulk Samples in the Lab from the Field

Bulk sample non-diagnostic redundant artifacts/fossils may be considered to be of insufficient interest when, on a case-by-case basis the permitted principal investigator can document the above listed criteria are met.

## Manner of Transfer or Disposal

Always follow and explore this order of options when considering transfer or disposition of non-diagnostic material:

1. *Transfer to another non-profit educational/cultural organization, Indian tribe or governmental agency.*
2. *Other entity donation (name and organization). There must be a public benefit.*
3. *Destruction (final choice only; describe the method and how all other options have been exhausted).*

## Administrative Record of the Disposition Required

After the approved repository and the permitted principal investigator has made a recommendation of disposition, the principal investigator and the repository representative must document this determination. The State-Approved repository must retain an administrative record of all disposition actions for a minimum of one hundred years.

The administrative record must document the rationale for the disposition. Paleontological collections that are too fragmented to determine an identifiable element (i.e. femur, shell etc.) by consensus with a principal investigator and the repository can be disposed of if all other options have been considered.

The disposition action should include specific information (such as):

- a description and evaluation of the non-diagnostic objects;



# Guidebook for State-Owned Collections

---

- the method of disposition and the reason for the method chosen;
- names and titles of persons initiating and approving the disposition;
- date of the disposition;
- relevant field or catalog numbers (if assigned);
- evidence of the receipt for the return, transfer, or conveyance of the material remains by the recipient tribe, agency, repository, or institution, including the title to the received material remains, (if applicable);
- photographic documentation, (as appropriate);
- and the name and location of the recipient institution or entity, (if applicable);

The administrative record must be included with the collection's deposited associated records (e.g. field notes and final report). If a sample is to be retained for future studies, a description of the samples must be listed as part of the full collection inventory.

After disposition, the accession and catalog records must be reviewed and amended through a procedure established by the approved repository. The amendments must identify the artifacts/fossils that were deaccessioned and disposed of, the date of disposition, and the manner in which they were disposed.

## **Form and State Archaeologist's Approval Required**

The repository director or top management official and the qualified permitted principal investigator (archeologist/paleontologist) must fill out and sign a "Disposal of Non-Curated State Collections Form (#1661)" to be forwarded and signed by the State Archaeologist acting on behalf of the State Historical Society's (i.e. History Colorado's) President and Board of Directors to document the approval of the transfer or disposal action. The signed and completed form must be forwarded the State Curation Coordinator for tracking purposes.

## **Transfer of Non-Curated Collections Receipt Form**

If after completing the "Disposal of Non-Curated State Collections Form" and the artifacts or fossils will be transferred to a non-profit educational/cultural organization, Indian tribe or governmental agency or other entity with a demonstrable public benefit, the "Transfer Receipt Form (#1662)" must be completed. The signed and completed form must be forwarded the State Curation Coordinator for tracking purposes.

## **Items for Repatriation or Re-burial**

All items designated for repatriation or reburial under Federal Law 101-601 (Native American Graves Protection and Repatriation Act, 25 USC section 3001 et.seq.[NAGPRA] or in compliance with State statute C.R.S.24-80-1301 (Unmarked Human Graves) and Section 13 of the State Rules and Procedures 8 CCR 1504-7 must first be reported and approved by the State Archaeologist.

### Notes on non-repatriated artifacts/fossils for re-burial consideration

As a matter of general policy the Office of the State Archaeologist objects to the practice of artifact re-burial. Under State law C.R.S .24-80-401-411, archaeological and paleontological resources that are excavated or removed from non-Federal public lands remain the property of the State of Colorado and such resources as well as copies of associated records and data must be preserved at a museum or an on-site repository unless approved by the State Archaeologist. Re-burial without proper documentation may disturb the existing context of a site or create problematic deposits for future researchers.

Furthermore, according to the Colorado Council of Professional Archaeologists and the Register of Professional Archaeologists Standards of Research Performance, *a research archaeologist must ensure that specimens and research records resulting from a project must be deposited with an organization with permanent and adequate curatorial facilities, and which permits access by qualified researchers* (CCPA V, RPA Sec. V). Likewise one ethical principle of the Society for American Archaeology states that *archaeologists should work actively for the preservation of, and long term access to, archaeological collections, records, and reports* (SAA Principle of Archaeological Ethics #7) The Society for Historical Archaeology also states that *archaeologists must see that materials are appropriately curated for future generations* (SHA Principle #4). Reburial of State artifacts or fossils therefore without express approval by the State Archaeologist is unlawful and may violate professional ethical principles.

# Guidelines and Procedures

## 5. Standard Requirements for Curation Agreement Templates

History Colorado's State-Approved Museums and Curatorial Repositories Program allows approved museums or curatorial repositories (collectively "approved repositories") to charge a reasonable administrative fee for processing "curation" or similarly worded "intent-to-curate" agreements with permitted researchers. If the approved repository curates collections from external permitted researchers, a copy of the curation agreement template must be submitted to the State Archaeologist or their designee for approval (8 Colo. Code Regs. § 1504(9)). In an effort to give greater guidance to approved repositories, History Colorado created these standards for developing such agreement templates with permitted researchers.

### State of Colorado Curation Agreement Template Requirements:

1. All agreement templates must cite the Historical, Prehistorical, and Archaeological Resources Act and its implementing regulations (Colo. Rev. Stat. §§ 24-80-401 and 8 Colo. Code Regs. § 1504) when referring to any statute or regulation supporting the requirements governing a curation agreement. Do not only cite Federal regulations (i.e. 36 C.F.R. § 79) as the Federal regulations do not govern State collections.
2. All agreement templates must clearly acknowledge that the State of Colorado retains title to artifacts or specimens collected from non-Federal public lands as well as all associated reports, original field notes, maps, drawings, photographs etc. (8 Colo. Code Regs. § 1504).
3. All agreement templates must require permitted researchers to deliver all collections (archaeological or paleontological) made from non-Federal public lands in accordance with the current *Submission Guidelines for State-Owned Archaeological Collections (#1636)* and 8 Colo. Code Regs. § 1504. If the collections are not prepared according to these standards, then the permitted researcher may be subject to the costs incurred by the approved repository to cure any deficiencies.
4. All agreement templates must require permitted researchers to return a fully signed official state deposit receipt from the approved repository, accompanied by a simple inventory list of items accepted by the approved repository for curation, to the State Archeologist.
5. All agreement templates must be signed and dated by the permitted researcher, or designated representative of the archaeological or paleontological firm (with their work title) and the title, date and signature of the approved repository representative.
6. Curation agreements with permitted researchers must never be made perpetual. Such agreements must be renewed within five years or less of issuance and will remain valid only so long as the repository retains its State-Approved status.

It is recommended that any curation one time deposit fees adopted by the approved repository (allowed under 8 Colo. Code Regs. § 1504) be cited and attached to the curation agreement so that the permittee can budget accordingly when developing a research plan and collections strategy.

Approved repositories may follow up the curation agreement for the permitted researcher with a more specific contract for services or memorandum of understanding detailing the repository's specific requirements (in addition to any State requirements), however any subsequent contract or memorandum

## Guidebook for State-Owned Collections

---

must incorporate and be subject to the original curation agreement. All such contracts or agreements must be forwarded to the State Curation Coordinator for approval.

Please submit any new or changed “curation” or “intent-to curate” template to the State Curation Coordinator at [HC StateCuration@state.co.us](mailto:HC_StateCuration@state.co.us)

# Guidelines and Procedures

## 6. List of Official Forms and Guidelines

Form #1308 - Rules and Procedures

Form #1426 - Request to Serve as a State-Approved Museum or Curatorial Repository for Held-in-trust Collections from Lands Belonging to the State of Colorado or its Political Subdivisions

Form #1629 - State-Approved Museum and Curatorial Repositories List

Form #1636 - Submission Guidelines for State-Owned Archaeological Collections

Form #1645 - Official Receipt for Deposit for State of Colorado Held-In-Trust Collections from an Approved Museum or Curatorial Repository for Specimen and/or Artifact Curation

Form #1645a - Inventory Template (Excel)

Form #1646 - History Colorado Curation Agreement and Deposit Fee

Form #1647 - Request for Destructive Analysis Approval of Held-In-Trust Artifacts or Fossil Specimen

Form #1648 - Reference Guidebook for State-Owned Collections Care

Form #1649 - SAA Guidelines for Preparing Legacy Collections for Curation

Form #1650 - Repository Collection Policy Template

Form #1651 - PREP Emergency Plan Template

Form #1652 - DMNS Anthropology Department 2019 NEH Archaeology Rehousing Workflow

Form #1653 - DMNS Department of Anthropology Regular Box Re-Housing Instructions

Form #1654 - DMNS Mount Making Cutting Tool Calculator (Excel)

Form #1655 - List of Potential Thesis/Dissertation/Capstone Subjects with State of Colorado Archaeology or Paleontology Collections Needing Re-housing Care, Re-analysis or New Interpretational Opportunities

Form #1656 - Request for Non-Destructive Out-of-State Transportation Approval for Held-In-Trust Artifacts or Fossil Specimen

Form #1657- List of Sites with Repository Names (Excel)

Form #1658 - Outgoing Loan Agreement Guidelines for Held-In-Trust Collections

Form #1659 - Permitted Archaeologists' Guide to the State-Approved Repositories Program

Form #1660 - Guidelines for the Disposition of Non-Curated State Collections From a Research Lab or a Museum/Repository

Form #1661 - Disposal of Non-Curated State Collections Form

# Guidebook for State-Owned Collections

---

Form #1662 - Transfer Receipt Form

Form #1663 - State of Colorado, State-Approved Museums and Curatorial Repositories Curation Survey and Plan

Form #1664 - Standard Requirements for Curation Agreement Templates

# Reference Materials and Guidance

## 1. Repository Collections Policy Template

### Repository Collection Policy - Template

Based off American Alliance of Museums *Developing a Collections Management Policy* (2012)

#### Mission

[State the mission of the repository and what it hopes to accomplish with its collections, such as research opportunities for students or researchers, and preserving collections]

#### Vision

[What you and others wish to see happen with the repository and collections, including current and future visions]

#### Statement of Authority

[Who manages the collections? Who assists with the collections? Where are they housed? Who is the governing body associated with the repository institution and collections? Answering these questions provides a line of authority and responsibility for the repository's collections, state-owned collections, and federal-owned collections]

#### Code of Ethics

[Both institutions and organizations follow different (or similar) ethics that are associated with collections, and historical and prehistoric materials – whether that be archival, archaeological, ethnographic, paleontological, environmental, or other applicable materials; these ethics can be searched online, with the Statement of Professional Standards and Ethics (June 2012) by the American Association for State and Local History (AASLH) serving as a good outline for applicable ethics to an institution]

#### Scope of Collections

[Here is where you will state what the purpose of your institution is in regard to the collections you are currently housing, including archives, archaeological collections, museum collections, and associated documents or materials, as well as a brief overview of what is contained in your collections, which will be expanded upon in the next section]

#### Types of Collections

[This provides you the opportunity to state the collections you have, including archival or library collections, education (collections used for educational purposes), exhibition (collections used for exhibits), permanent (collections in the institution's care that will remain in their care), research (collections used by students or researchers for research), or collections held under a repository or

# Guidebook for State-Owned Collections

---

management agreement (i.e., state- or federal-owned collections); also include how these collections are used, acquired, and cared for – a brief explanation will do, but enough to describe what is in your care]

## **Acquisitions/Accessioning**

[State your policy for acquiring collections and accessioning them, legally adding them to an institution's database or collections; here, institutions will outline the criteria and decision-making process, and involved institution parties involved with acquiring and accessioning collections]

## **Deaccessioning/Disposal**

[State your policy and reasoning behind deaccessioning/disposing of collections or materials, this will usually involve a collection not applying to an institution's mission, allowing the institution to deaccession and transfer collections to an institution that could make use of these collections, or disposing of these collection with proper reasoning or criteria met; also outline the methods of deaccessioning/disposal from databases, removing the physical collection, and documentation of the process]

## **Loans**

[Outline how potential borrowers of institutional collections may loan out certain collections and which collections are available for loan – this will usually include a Loan Agreement Form (these can either be internal for research, teaching, or exhibition, or external for the same reasons); Condition Reports are also a good idea to document the collection/material before and after the loaning period]

## **Conservation/Care**

[What do the rooms/areas where collections are stored look like? What is the environmental control for the room? Are there pest control methods? How do you conserve the collections or materials? How do volunteers and staff handle the artifacts? Providing this information gives a base line for storing and caring for collections in the institution]

## **Insurance and Risk Management**

[Does the institution have insurance on the collections? What is the insurance policy for the collections? Fire detection and fire suppression? Security? Other risk management in the storage facilities? Mentioning an Emergency Response Plan here will also help and can provide more details on the brief summary provided here for risk management]

## **Documentation, Collection Records, Inventories, Objects in Custody, and Conservation/Care**

[What documentation and records are there for collections? Are they physical and where they stored? Or are they on a database? Also, how will the institution handle objects that are abandoned or do not have a clear connection to a collection? How will the institution care and conserve objects and collections? This section provides further information on the collection and how the institution handles them, and the information associated with them]



# Guidebook for State-Owned Collections

---

## Access

[Who has access to these collections and their records? Are they available to the public or researchers? Are they available for educational purposes? States who handles the collections for the institution/repository and who, outside of the institution/repository, is allowed to handle them]

## Appraisals

[Appraisals can help with identifying parts of collection and insurance policies for the collections; outline who can appraise the collections and the process of bringing in a specialist for appraisal, if needed]

## Legal and Ethical Considerations

[A brief examination of laws that pertain to holding collections and objects may be helpful for this section, such as NAGPRA (1990), NHPA and Section 106, and local or state regulations; for a brief summary of some of these laws, they refer to objects or artifacts that are: stolen, looted or reappropriated art, archaeological material removed from federally owned or controlled land, and issues relating to the Native American Graves Protection and Repatriation Act (NAGPRA); also a place to state that no selling of collections or objects will be considered or carried out for profit]

## Intellectual Property

[Addresses copyright and intellectual property laws that pertain to certain objects or collections, being aware of said laws, and how the institution will handle accepting (or not accepting) these objects or collections]

## Review/Revision

[A section identifying when and why updates may need to be applied to an institution's collection management policy, and who will carry out this process of review and revision]

## Glossary

[A brief glossary of terms and vocabulary used in the collections management policy for staff, volunteers, and board members to review]

## For State Collections:

### ***Section 9 (2017)***

Section 9 of the Historical, Prehistorical, and Archaeological Resources Act of the State of Colorado provides rules and procedures for housing State Collections by a State Repository (note that Section 9 is available for review at [historycolorado.org](http://historycolorado.org) under "State-Approved Museums and Curatorial Repositories"). Below is listed a summary of Section 9 and should be considered or referred to before any memorandum, agreement, or consideration to house a State Collection. What your institution plans to do with State Collections, whether current or future, should be stated within your Collection Policy. When the next chance to update your Collection Policy appears, any addition of a State Collection (in general) should be stated and addressed accordingly. Section 9 details this process, but here is a condensed guide on what needs to be considered when preparing for a State Collection (note that State Collections WILL BE held in perpetuity – pay attention to this in any contract, memorandum, or agreement; *be prepared for this*):

# Guidebook for State-Owned Collections

---

## State Repository Curation:

- Colorado owns any collections (historical, prehistorical, and archaeological) from areas owned by the state or any of its political subdivisions;
- Institutions who wish to enter a partnership for State Repository-status will also be entering a collaborative partnership with the State of Colorado in interpreting, preserving, and education (if applicable) of these collections;
- These collections, unlike Federal Collections, must be accessible to the public and available free of charge for study by qualified students and researchers, this includes:
- Having a relevant insurance policy relating to the institution regarding fine art or material culture, or acknowledging that State-Owned collections are covered for liability from any loss or damage, as they are state property;
- Intent-to-Curate agreements by State Repositories to third-party researchers must have their agreement language approved by the State Archaeologist or his/her staff;
- Within 10 days refer all written or oral transfers or repatriations of a state collection to the State Archaeologist of Colorado;
- DO NOT release any location information on the Collection to any third party, except to qualified researchers or receiving written permission from the State Archaeologist of Colorado;
- Be open and subject to inspection by the State Archaeologist or his/her designee at least once every three years;
- Accept State Collections related to specific regional or local area guided by these rules and the State Repository's Collection Management Policy;
- Annually report the State Collections condition, insurance policy changes, loan agreement status, and "any other tracking requirement methods adopted by the society and the Office of the State Archaeologist"
- Properly maintain State of Colorado property associated with the care of the State Collection
- Maintain proper storage practices, such as acid-free storage or packaging
- Must receive written permission from the State Archaeologist to: repatriate, not sell, transfer, assign, pledge, encumber, discard, or otherwise dispose of any part or the whole of the State Collection;
- Established Collections Management Policy and Emergency Management Plan

## Approval for State Repositories:

- Must apply through the State Archaeologist;
- Fill out a *Request to Serve as an Approved Museum or Curatorial Repository for Held-in-Trust Collections*
- Approval of a State Repository shall be effective for 5 years, after which time the Repository may apply for renewal through Section 9 procedures
- An official deposit receipt of State Collections and agreement must be signed to acknowledge that the State Repository is in-holding of the State Collection

## Resources Cited:

### American Alliance of Museums (AAM)

- 2012 *Developing a Collections Management Policy*. Department of Higher Education of Colorado
- 2017 *Historical, Prehistorical, and Archaeological Resources Act: Section 9. Curation of Collections in Approved Museums*, electronic document.  
<https://www.historycolorado.org/state-approved-museums-and-curatorial-repositories>, accessed October 16, 2019.

# Reference Materials and Guidance

## 2. Pocket Response Plan

The Pocket Response plan is a printable document that outlines the response to an emergency in regards to the collections held by the repository. The document is one sheet of paper double sided that will be placed in a waterproof sleeve. Side A holds all the necessary contact information for individuals and organizations that will need to be contacted during the first minutes and hours of an emergency. Side B has all the appropriate responses for particular types of emergencies and includes who should be contacted from Side A. Several copies should be kept in well-known places as well as alongside your comprehensive emergency plan. This does not negate the need for a comprehensive emergency plan, but rather includes all of the most immediate actions to be taken in an accessible one sheet format. A sample pocket emergency plan is pictured below; to edit and print the form find it [here](#) on History Colorado's website.

**SIDE B (Actions).** Use this side to provide step-by-step instructions for library and affiliated personnel who will respond to a disaster affecting your own institution. Ideally, steps should already be defined in the library disaster plan. This document is NOT intended to be a substitute for a comprehensive emergency plan. Instead, it should distill the most important tasks to be taken in the first minutes and hours after an emergency occurs.

**Checklist for Collections Recovery**

**IMMEDIATE RESPONSE** (as appropriate):

- First Responders
- Secure and seal all collection areas
- Monitor security of building and collections
- Control access
- Activate the Disaster Plan's emergency response actions
- Communicate "name of collection damage"
- Follow other Communications steps

**WATER RESPONSE**

- Water source, remove standing water
- Cover collections with plastic
- Remove liquids from water path, unless toxic liquid

**WATER RESPONSE**

- Identify materials needing water
- Remove water from collection (e.g., books, film, etc.)
- DRY (consulting an expert)

**WATER RESPONSE**

- Obtain appropriate permissions to help with water damage (e.g., public health, structural engineer)

**WATER RESPONSE**

- Obtain appropriate permissions to help with water damage (e.g., public health, structural engineer)

**WATER RESPONSE**

- Obtain appropriate permissions to help with water damage (e.g., public health, structural engineer)

**SIDE A (Communications).** Use this side to collect phone numbers for the individuals and organizations who are most likely to need to talk to, talk to, or be notified by, in the first minutes and hours after an emergency occurs: staff, emergency responders, facility managers, utilities, vendors, and assistance organizations.

**Print on 8 1/2" x 14" paper. Trim on outside lines to 12 1/2" x 6 1/2", fold on vertical lines like an accordion, then fold in half (bringing short sides together) so that final folded document measures 2 1/2" x 3 1/2".**

**Insert in PPR™ Tyvek® envelope for protection, available from CoSA <http://www.statearchivists.org>. © 2006 Council of State Archivists (CoSA). Adapted by WESTPAS.**

**Print on 8 1/2" x 14" paper. Trim on outside lines to 12 1/2" x 6 1/2", fold on vertical lines like an accordion, then fold in half (bringing short sides together) so that final folded document measures 2 1/2" x 3 1/2".**

**Insert in PPR™ Tyvek® envelope for protection, available from CoSA <http://www.statearchivists.org>. © 2006 Council of State Archivists (CoSA). Adapted by WESTPAS.**

## Reference Materials and Guidance

### 3. Collection Labeling and Packaging Guidance

Print Edition 1.2  
August 2010

#### Collection Labeling and Packaging Guide Antonio J. Waring, Jr. Archaeological Laboratory

Archival labeling and packaging of objects, or groups of objects, are essential for the preservation and use of materials within an archaeological collection. Proper packaging and labeling ensures that collection information, most importantly those associated with the object's provenience, is maintained and accessible. A curated archaeological collection and its component parts are not simply warehoused. The information contained within each collection has continuing value and is used for a wide variety of purposes, including scholarly research, specialized analysis, heritage education, and public exhibition. On many occasions, an individual object or small group of objects needs to be removed temporarily from the collection. A well organized collection, properly labeled and packaged, effectively limits the possibility of information loss that can occur when an object has to be separated from its associated collection.

The information provided in this Guide is meant to supplement, but not replace, the *Standards for Archaeological Curation* for curation at the Waring Laboratory. The labeling and packaging measures detailed here conform with standards defined in *Curation of Federally Owned and Administered Archeological Collections* (36 CFR 79) and are compiled from information primarily derived from the American Association of Museums, the U.S. Army Corps of Engineers (St. Louis District), and the National Park Service. The Waring Laboratory recognizes that variant methods and materials may be required due to the specific nature of a collection and its parts. Departures from the specifics outlined in this Guide may be acceptable, if necessary and justified, as long as professional archival standards<sup>7</sup> are maintained and the alternate methods preserve provenience information and facilitate use of the collection. Any variance must be approved in advance of depositing the collection with the Waring Laboratory. Archaeologists should consult the National Park Service's *Museum Handbook* (especially Part I, Museum Collections) ([www.cr.nps.gov/museum/publications/handbook.html](http://www.cr.nps.gov/museum/publications/handbook.html)) and *Managing Archeological Collections: Technical Assistance* ([www.cr.nps.gov/aad/collections/index.htm](http://www.cr.nps.gov/aad/collections/index.htm)) for additional information.

#### Cataloging

Each collection must be accompanied by three copies of a clearly identified Artifact, Document, and Photo Catalog in archival printed form and on a PC

formatted disk or CD in a *Microsoft Excel*® or ASCII tab-delimited file format.

#### Cataloging Artifacts

The Waring Laboratory does not mandate the specific type of artifact catalog system used. Catalog groups may be defined by analytic categories or classifications more specific than that provided by material class identification. Regardless of the artifact catalog type, the artifact catalog must have a unique catalog number for each catalog record and include a quantified *count*, a *description*, associated *provenience information*, *excavation date*, and *site number* (if available). The artifact catalog must clearly reflect the organization of the artifacts so each inner artifact bag contains only one unique number and be identified on the artifact catalog with that same number. Counts are required for all material except crumbling bone, fractions, charcoal, and C-14 samples. Weights are recommended for all material except for C-14 samples. Additional columns may include measurement, field number, restrictions, and other essential information. Refer to the table below for an example.

Mandatory Artifact Catalog Fields						
Unique #	Prov.	Description	Date	Count	Weight	Site #

#### Cataloging Photos

The photo catalog must include a unique photo identification number (field number if non-digital or file name if digital), date the photo was taken, provenience information (site, feature number, and/or location), description, photographer's name, camera used, project name, and format (i.e., tiff, 35mm).<sup>13</sup> Digital photos are accepted, but all unnecessary photos must be culled and not included in the collection (i.e., pictures of pets and fun in the field).<sup>13, 11</sup> It is not necessary to document which photos were discarded. Any altered images must be noted. The preferred format for digital photos is .tiff, which can be changed to be the default on most cameras.<sup>13</sup> The digital photo's file name must serve as the unique photo catalog number to allow proper correlation between the photo and the digital data.<sup>1</sup> An electronic listing of all files within a PC folder directory can be generated with the command: "*dir > filename.txt*" at the command prompt. Then the files can be cut and pasted from the "filename.txt" file into a spreadsheet program.



# Guidebook for State-Owned Collections

Print Edition 1.2  
August 2010

## Cataloging Documents

The document catalog minimally must have a complete description, document creation date, and folder number. An example of a document inventory with multiple projects and suggested categories is shown below. Other specific or additional categories may be required.

Document Catalog		
COLLECTION INFORMATION:		
ACCESSION NUMBER	_____	
COLLECTION OWNER	_____	
PROJECT# / SITE NAME	_____	
OFFICIAL STATE SITE # (s)	_____	
<i>SubCollection #, Folder#</i>	_____	<i>Date</i>
1.1.	Artifact Inventory From Site 9JA318	2/14/1999
1.2.	Field Notes By John Doe	SUMMER 1999
1.3.		
	Project Map	JUNE-Aug. 1999
1.4.	Bound Report: <i>Report Title</i>	August 1999
1.5.	Provenience/Bag List For 9JA318	
2.1.	Field Notes By Jane Doe	
2.2.	Provenience/Bag List For 9JA318	
2.3.	National Register Of Historic	
2.4.	Correspondence Regarding <i>Subject</i>	August 1, 1999
2.5.	Permits	
2.6.	Photos – Black And White	
3.1.	Photos – Negatives	
3.2.	Photos – Slides	
3.3.	Research – (Bibliographic)	
3.4.	CAD Drawing On CD-ROM	Sept. 2000

## Labeling

Labeling involves directly labeling and placing a tag inside the storage container with the object. This section defines approved archival materials, identifies when to directly label artifacts, what information is to be included on tags, and how to label associated documentation. All artifacts and associated documentation must be clearly labeled using professional standards and appropriate archival materials for the medium. As previously stated, variations may occur and are handled on a case-by-case basis. Consult with the curatorial staff at the Waring Laboratory when the need for variant materials or methods is identified. The materials and methods that are used for labeling must be documented fully on the *Collection Summary Form*.

### Materials:

Below is a list of materials that may be used for labeling and some that are to be avoided.<sup>4</sup>

Materials that may be used	Materials that cannot be used
100% cotton string, undyed	Typewriter correction fluid
Teflon monofilament	Nail polish
Nylon monofilament in polyethylene tubing	Rubber cement
Acid-free 100% cotton rag paper	Pressure sensitive tape or labels
Unbuffered paper with a neutral pH, high alpha cellulose, lignin free	Paper labels moistened by water
Japanese paper	Ballpoint ink
Tyvek®	Metal fasteners or tags
Cotton twill tape	Edged tags
India Ink	Silicone products
Acryloid B72 or B67	Chalks
PVA	Fusible iron-on fabrics
Pencil	Wire
Acid-free card stock	Elmer's® glue
Reemay®	Nail polish remover
Mylar®	
Alcohol and acetone solvents	

## Labeling Artifacts

Every item should be labeled with its associated catalog number as applicable to its material and status in the collection, yet be reversible if the label must be removed or changed.<sup>4</sup> Directly labeled artifacts are less likely to lose their provenience information or to be separated from their catalog number than are artifacts that only have catalog numbers on paper labels or labeled containers.<sup>4</sup> It is crucial that this identifying number not be separated from the specimen. For this reason, objects that can be safely labeled directly should be. All diagnostic artifacts and a representative sample of non-diagnostic artifacts submitted for curation must be directly labeled with associated catalog numbers. These classifications are determined by the Principal Investigator (P.I.) of the project.

All diagnostic artifacts must be directly labeled when possible, either with the reversible “sandwich” technique described below or, when the material dictates, with a small label attached to the artifact with archival string. “Diagnostic” artifacts are identified and defined by the professional archaeologist who recovered the material and include many of the items that comprise an archaeological collection.<sup>4</sup> A representative sample (as defined by the Principal

Print Edition 1.2  
August 2010

Investigator) of non-diagnostic artifacts of each material class from each provenience also must be directly labeled with associated catalog numbers. Material classes define groupings of artifacts into elementary classification categories such as lithic, animal bone, ceramic, glass, etc. Listed below are a few examples of “Diagnostic” and “Non-Diagnostic” artifacts solely for illustration since the P.I. determines material class.<sup>4,7</sup>

## “Diagnostic” Examples

### Prehistoric Artifacts

Pottery – complete and partial vessels, plain sherds, decorated sherds, rims, basal sherds, lugs, handles.  
Lithics – points, blades, scrapers, drills, performs, blanks, utilized flakes, celts, atlatl weights, hoes, other ground-stone objects.  
Bone – identifiable animal bone, bone tools, worked or cut bone.  
Exotic Raw Material – non-local (imported) manufacturing materials.

### Historic Artifacts

Ceramics – complete and partial vessels, plain sherds, decorated sherds, rims, basal sherds, sherds with maker’s marks, buttons, pipe bowls, pipe stems, marbles, doll or figurine parts.  
Glass – cut, pressed, decorated, vessel bases, lips, handles, fragments with labels or manufacture’s marks, complete and partial vessels.  
Metal – tools and large fragments, machine parts, building hardware, buckles, ornaments, jewelry, flatware, harnessry, other implements.  
Plastic/Rubber – vessel parts, tools/implements, toys.  
Bone - identifiable animal bone, bone tools, worked or cut bone

## “Non-Diagnostic” Examples

Non-utilized lithic flakes, shatter, and other debitage.  
Shell fragments (if not worked or utilized).  
Small, indistinguishable glass fragments.  
Fire-cracked rock.  
Clinkers and slag.  
Construction debris (brick fragments, mortar, etc.).

The method used to label an object depends on a variety of factors. These include physical stability of its surface, roughness, porosity, physical strength, and flexibility. It is important to use methods and materials that are appropriate to the object and do not harm it in any way.<sup>4,2</sup> The catalog number should be placed in an area that does not impact important diagnostic or aesthetic features of the object, and minimizes the handling needed to view the number. The most common method for directly labeling objects is a “sandwich” technique. Steps for this method are:<sup>2</sup>

1. Clean (if necessary) the area to be labeled.
2. Place a thin coat of clear reversible lacquer (e.g., Acryloid B72 or B67) on the labeling area. If the artifact is dark in color, use white lacquer for the base coat. Multiple applications may be necessary on porous objects, such as unglazed ceramics. Let the base coat dry thoroughly.
3. Write the label information on top of the base coat using a permanent water- or pigment-based ink (e.g., India ink). Let ink dry completely. Apply a topcoat of clear varnish (e.g., Acryloid B72).
4. Let the label dry thoroughly before placing the object in a container.

It is possible to remove a label if it is incorrect or applied in the wrong location. If a base coat and inked label have been applied, the ink may be removed with a cotton swab slightly moistened with water. This will not affect the lacquer base coat for the application of a new number. If all three layers have been applied, the lacquer and ink may be removed with careful application of the solvent acetone by rolling it on the label with a cotton swab.<sup>2,9,10</sup>

Some objects cannot be labeled directly using the sandwich technique. They may be too small or have unstable surfaces [e.g., rusting metal nails]. Most paper, basketry, leather, textiles, and wood should not be marked directly.<sup>4</sup> Human remains must not be directly labeled.<sup>7</sup>

In addition to direct labeling, artifacts must be accompanied by an archival stable tag (such as 25% cotton and acid-free paper, or Tyvek®) placed within the bag or other storage container. Tags of different sizes and shapes can be used for the catalog group to fit the appropriate size plastic bag or other container. Tags that may become worn or dirty must be sealed in a plastic bag within the artifact bag to protect it. Tags must not be folded. The tags can be directly printed from the artifact catalog or handwritten. Pencil or archival ink (e.g., pigma pen) must be used on the labels if the tags are handwritten.<sup>2</sup> Inner container tags must be labeled minimally with the project name, excavation date, site number, provenience information, description, and catalog number. Outer container tags must be labeled minimally with the project name,

# Guidebook for State-Owned Collections

Print Edition 1.2  
August 2010

excavation date, site number, provenience information, and catalog number(s). See the figure below for an example.

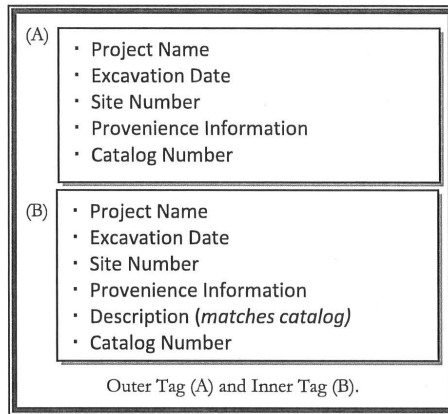

Extremely large objects and special samples may require individual identification tags. Acid-free tags may be attached to large objects by tying or sewing. Identification tags for special samples can be placed in the sealed container with the sample or on the housing of the container. When attaching labels, use materials compatible with the object and its storage location. In general, string or thread should be softer than the artifact's surface, should not cut through or into the object, should not be attached too tightly, and should not be colored or dyed.<sup>2,4</sup>

## Labeling Documents

Proper labeling of associated records such as photographs, audiovisual materials, digitized data, and field notes is essential. It provides a means to relate one or more records to specific objects or collections in order to obtain contextual information about particular material remains or other analytical information. Again, labeling techniques, as well as the amount of information on the label, depend on the media.<sup>4</sup>

Paper records must be in 100% acid-free and lignin free folders.<sup>2,4</sup> Each folder must have a folder number handwritten on it with either a carbon ink pen or pencil. If paper documents must be directly labeled, identifying information should be applied neatly in very small capital letters in the same location on each sheet such as a reverse edge. If using pencil, such as a #4 graphite (2H), use a dull point and apply very little pressure.<sup>6</sup> Critical information on the label includes

collection name and/or number, box number, and file number. A unique file title and date may also be included.<sup>1</sup>

Supplementary information may be submitted electronically (i.e., CAD, GIS). A printout on acid free paper must be provided of all information provided electronically. A statement describing the software along with the version used and disk content must be provided. Archival CD-Roms (rated 100+ years) or a floppy disk may be submitted. Typed or computer generated archival adhesive labels should be used for audiovisual materials on tape or reel and for electronic diskettes. These labels must contain the collection name, the unique identifying number (i.e., folder number), a brief description of the contents, and software name, version, and size.<sup>2,4</sup>

## Labeling Photos

Labeling photographic materials begins with proper handling. It is always wise to wear gloves (cotton or nitrile) since the acid on fingers may cause permanent damage. Each image (negative, slide, or print) must be stored in its own envelope or sleeve made of inert plastic (no PVC) or interleaved with acid-free, lignin free high alpha cellulose unbuffered paper.<sup>2,4</sup> All photos, slides, and negatives must be cataloged with a unique number. This unique number must be written on the back of all photos and on all slide mounts.<sup>2,5,11,13</sup> Do not write on the negatives. Prints also may be labeled directly in the border area of the reverse side, using indelible or permanent ink. Care should be taken to minimize the pressure applied when writing since it can cause the emulsion to crack.<sup>4,6</sup>

All digital photos must be printed both on (1) a thumbnail contact sheet with the attached file name<sup>13</sup> and (2) in larger format no smaller than 3" x 5". A digital copy of the photos must be provided. If CD-ROMs are used, they must be rated to last 100+ years. A photo catalog must accompany the photos refer to Cataloging Photos for specifications.

## Packaging

Archaeological material comes in many shapes and sizes, and highly diverse types of material usually are found in a collection. Few hard and fast rules exist when preparing to package a collection for curation and to explain every variation is beyond the scope of this Guide. This document will identify materials that may be used and outline basic guidelines for packaging artifacts, documentation, photos for curation with the Waring Laboratory. A primary goal of proper packaging is the safety of each object in the collection. Many packaging decisions rely on common sense applications to avoid breaking, abrasion, and deterioration of objects in the collection.



# Guidebook for State-Owned Collections

Print Edition 1.2  
August 2010

Each collection is considered individually and must be packaged in separate boxes. However, special arrangements may be made for collections comprised of multiple small projects. A complete inventory of all of the artifacts and documentation must accompany each archaeological collection. The catalog may serve as the inventory for the artifacts. A packing list at the folder or artifact-level must be included in each archival curation box. Each box must have a temporary label taped on one end with the collection name, a summary of the box contents, and box number (e.g., Box 3 of 5).

Artifacts and documents are packaged separately in standard Hollinger® type archival boxes (with a separate lid) measuring 15" x 12.5" x 10". The maximum allowable weight of each box and its contents is thirty (30) pounds and the box must be packaged so artifacts are not crushed. The contents of each box (regardless of total weight) must be well organized, readily accessible, not crushed, and packaged in a way that allows individual bags or documents to be easily removed and accurately replaced.

## Materials

The material used for packaging must be appropriate for the kind and size of the object or document. All materials used for packaging must be inert and acid-free. The table below identifies some of the materials that should, and those that must not, be used for packaging. Although the materials listed in the left column are considered archival, not all of them should be used with certain material classes of artifacts.<sup>4</sup>

Packing Materials that may be used	Packing materials that are not acceptable.
Acid-free boxes	Cigar boxes or regular cardboard boxes
Polypropylene containers	PVC or "plastic" containers
Acid-free poster board	Acidic cardboard
Polyethylene foam	Styrofoam
Heavy Weight Polyethylene bags with zip closure (e.g., 4mil thickness)	Plastic wrap
Polyethylene sheeting and chips	Polyurethane chips
Acid-free tissue paper	Toilet paper, facial tissue or newspaper
Polyester batting	Acidic paper
Tyvek® for labels	Brown paper bags
Aluminum foil without any additives (C14 samples only)	Cellophane tape
	Cotton wool
	Foam rubber, urethane foam

Metal containers (limited uses)	Masking tape
Glass containers (limited uses and insulated against breakage)	Rubber bands
Cotton or muslin fabric	Metal paper clips
Cotton or polyester batting	
Mylar®	
Lignin-free paper	
Ethafoam®	
Gelatin capsules	

## Packaging Artifacts

Minimally, material classes (e.g., lithic, pottery, glass, etc.) must be separated from one another in individual containers. More specific classification categories within material classes may be used when separating artifacts into individual containers. The artifact catalog must reflect the sorted organization of the collection, minimally at the level of material class. These material-class (or more specific category) containers then must be stored together in a larger container that includes all materials from a single catalog grouping or provenience (creating multiple inner and outer containers). Do not reuse dirty field containers. A container may be a polyethylene bag, small archival box, or polyethylene or glassine vial.<sup>4,2</sup> Select the size container that is appropriate for the object or group of objects. When using bags, a minimum of 4-mil polyethylene bags are required. Each bag must be no more than 2/3rds full. Bags must be broken into multiple bags (e.g., bag 1 of 3) if the bag is too full, or the artifacts are crumbly due to variation in size or fragility. Thicker bags or rigid containers should be used for heavy objects or objects with sharp edges, and padding should be added when necessary.<sup>4</sup> Acid-free tissue or polyethylene foam sheets may be used to provide an extra measure of cushioning for objects or to cover a sharp object that might otherwise tear the artifact container.<sup>4</sup> Artifacts must not be packaged in a way that would result in crumbling or crushing. Store very small and/or fragile objects (i.e., bone, seeds, shell) in a padded rigid container rather than in a bag.<sup>2</sup> All artifacts must be organized within each archival box in sequential groups of catalog numbers. Larger containers of micro-climate metal, flotation, shell, soil, and matrix samples collected during a project may be boxed separately from the artifacts. A micro-climate is a container that has a sealed climate and is defined in detail in the next section. Human remains and sacred objects must be stored in a separate box to provide the respect they deserve.<sup>4</sup> If a collection has a highly unstable or



# Guidebook for State-Owned Collections

Print Edition 1.2  
August 2010

oversized artifact, then the Waring Laboratory must be contacted as early as possible to identify if special environmental conditions are required.

## Basic Information for Packaging by Material Class

The Waring Laboratory performs an inventory for incoming collections to verify if an artifact is stable or unstable. Generally, artifacts are identified as unstable if they show evidence of debris due to crumbling, abrasion, breaking, and/or rusting inside its container. The stability of an object can usually be improved by wrapping it in appropriate acid free tissue paper, using a more rigid container, using special packaging or support, placing a silica gel packet with it, etc. Some artifacts may be highly unstable without conservation. Conservation practices, however, also may hinder some forms of analysis and the Principal Investigator should make informed decisions regarding specific conservation needs. Nevertheless, conservation must not be practiced without first consulting a professional conservator. Below is a list of material classes of archaeological artifacts with a guide to appropriate packaging for curation at the Waring Laboratory. This list is not exhaustive and additional requirements may be needed to ensure the stability of an object.

**Floral and Faunal Remains** - artifacts and ecofacts are often small, dry, fragile, and/or brittle. These frequently require sturdier containers like a box, vial<sup>4</sup>, or gelatin capsules. If the artifact needs to be wrapped, unbuffered Ph-neutral tissue paper must be used because the buffering agent (CaCO<sub>3</sub>) can react with the artifact, changing its pH.

**Ceramics (Historic and Prehistoric)** – Ceramics generally can be packaged together inside the same container. Unstable ceramics need to be wrapped in buffered acid-free tissue paper to stop abrasion. Larger ceramic pieces or vessels can be packaged inside a box supported with tissue paper or foam.

**Glass** - Glass fragments need to be packaged in heavy mil bags and/or wrapped with tissue paper or foam to prevent breaking or tearing the bag. Vessels and other whole objects should be individually wrapped and supported with tissue paper or foam.

**Lithics** - Most lithics are considered stable and can be packaged together inside the same container without additional medium. Care must be taken to prevent crumbling due to excessive weight and abrasion. Smaller flakes must never be packaged with larger heavy objects. Lithics can be wrapped in buffered tissue paper and/or subdivided into multiple bags.

**Metal** – All corroding and/or crumbling unstable diagnostic metal artifacts must either be

stabilized through electrolysis or placed in micro-environment. Non-diagnostic items must be packaged so as to reduce deterioration. Many different classes of metal artifacts exist. The most common are iron, bronze, silver, copper, and gold. Each class of metal requires a slightly different environment and must be packaged separately so that no one class is in direct contact with another. Metal artifacts showing active signs of deterioration must be packed in a desiccated microclimate designed for >20% relative humidity and loosely wrapped in acid free, unbuffered tissue paper.<sup>3,8</sup> A micro-environment is created by making a perforated pouch of silica gel. The pouch should consist of a polyethylene ziplock bag with small holes over its entire surface. Then place it on the bottom of a food-quality airtight freezer boxes made from polyethylene/polypropylene, such as those made by Rubbermaid® or Tupperware®. Two large Rubbermaid® Model No. 3863-87 boxes (approximately 36x26x13cm, 2.2 gallon/8.3 liter capacity) will fit neatly into a standard box with room.<sup>8</sup> For every 5 liters (5000 cm<sup>3</sup>) of volume within the container add 400 grams of silica gel.<sup>8</sup> Place the artifacts inside a ventilated plastic bag with their identification tag. Add a humidity-indicating strip that can be read through the container, in order to monitor the RH at the artifact(s).<sup>12</sup> Below are the general warning signs of instability associated with each class of metal artifact.<sup>3</sup>

- *Unstable iron* is identified as crumbly and shows signs of pits and/or active rust and leaves a red powdery residue on gloves or in the package.
- *Unstable bronze* crumbles and shows signs of pits and leaves a green powdery residue on gloves or in the package.
- *Tarnished silver* is relatively stable, as the patina acts as a protective barrier. Any newly formed abrasions that tear through the patina cause the rate of deterioration of silver artifacts to greatly increase. Therefore, the method of packaging needs to eliminate the possibility of scratching the silver artifacts during transportation and curation.
- *Copper* is highly reactive and difficult to stabilize. It leaves either a green or white crumbly residue on gloves or in the package.

# Guidebook for State-Owned Collections

Print Edition 1.2  
August 2010

Soil and Midden Samples - Heavy bulk samples should be double-bagged and packaged separately from the artifacts. All samples must be dry.

As previously mentioned, all inner and outer containers must be labeled in permanent ink using an extra fine Sharpie® pen.<sup>13</sup> The outside of each outer container must be labeled with the project name, catalog number(s), site number, provenience information, date of excavation, and any other essential information. The outside of each inner container must be labeled with the project name, site number, material class, catalog number, and other essential information. An archival identification tag (see Labeling) must be included inside each outer and inner container of artifacts so it is clearly visible. Identification tags in inner bags containing shell, metal, bone, soil samples, or other materials which may deteriorate or stain labels, should be placed first in smaller resalable bags to prevent contact with these artifacts.<sup>4</sup> The example below is demonstrated as bags, but labeling rules apply to other archival storage forms (i.e., boxes).

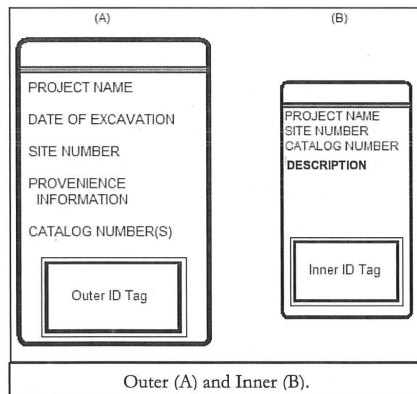

## Packaging Documents

Photographic and paper documents are highly sensitive materials and can be damaged by bending, folding, crushing, and off-gassing from the artifacts. Therefore, all documentation must be stored separately from the artifacts, regardless of how few artifacts are recovered.

All documentation must be organized by categories, clearly identified, and placed in archival folders or sleeves. Each folder must be labeled with the collection name, excavation date, documentation category, and folder number.

All documents are to be on acid-free paper or an archival copy should be packaged in folders separate from their original counterparts. Paper records must be placed in acid-free files and folders of appropriate sizes that are properly labeled.<sup>4</sup> Listed below are some general guidelines for packaging documents for curation at the Waring Laboratory.

Photographs, Negatives, Slides – Are to be packaged in polypropylene or polyethylene sleeves.<sup>4, 2</sup> A photographic catalog must be included.

Final Report – Three copies are required and one of these must be unbound.

Field Notes and Laboratory Analysis – The original and one archival copy of all field and laboratory documentation are required.

Catalogs – Three copies of the artifact, document, and photographic catalogs are required. A copy of each of these catalogs must also be provided on a PC formatted disk or CD in a Microsoft Excel® or ASCII tab delimited format.

Electronic Media (i.e., CAD, GIS) – May be included with the documentation and must be accompanied by a statement describing the system and software used and the content of each disk, tape, etc.

Maps, Large Drawing, Charts – Must be rolled or folded and properly labeled. Fragile and/or frequently used materials may require encapsulation in Mylar.<sup>4</sup> Maps on acidic paper should be copied onto acid-free paper whenever possible. Minimally, separate each map with a sheet of acid free tissue paper.<sup>4</sup> Contact the Waring Laboratory if any maps are oversized and are too large to conveniently and safely be placed in the standard archival box.

## Packaging Multiple Small Collections

Special arrangements may be made for packaging artifacts and documents that result in small collections from multiple projects. A small collection is defined as one that occupies less than five (5) linear inches of an artifact box (1/3 of an archival box). Multiple small collections may be stored together in the same box only if all of the collections have the same collection owner and with prior approval from the Waring Laboratory. Box labels and box inventories must clearly identify the number of small projects in each box.

Artifacts are packaged the same way as with larger individual collections, but each collection must be organized in the box so it is easy to distinguish one collection from another. Several methods are available for organization of multiple small collections. One method is to place each collection in a small archival box within the curation box. A second method is to use dividers or trays within the curation box. Dividers must be sturdy enough to prevent collections from becoming mixed during transportation. Acidic brown cardboard

# Guidebook for State-Owned Collections

Print Edition 1.2  
August 2010

is not acceptable because it off-gases and attracts pests.<sup>4,2</sup> Recommended forms of dividers are acid free blue-board or Coroplast™ (a plastic polyethylene board).<sup>4,2</sup> Dividers or trays can be purchased already put together or in sheets that can be cut and molded to preferred dimensions and shapes. Several ideas for dividers and trays are shown below.

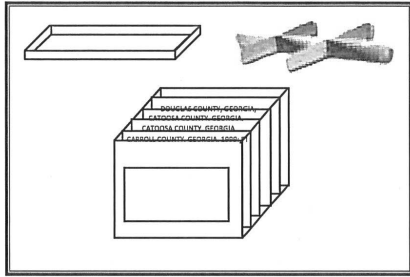

All documents for multiple small collections are to be packaged in a box separate from the artifacts. The documentation must be sorted and organized by each collection. A document catalog must be provided (refer to cataloging documents for details). Each folder containing documentation must identify the collection name, category, and folder number. It is preferred that folder numbers start over for each collection, in case the collection is ever moved.

## Delivery of a Collection to the Waring Laboratory

An approved *Request for Curation Form* must be on file with the Waring Laboratory before a collection can be scheduled for delivery. Schedule delivery to the Waring Laboratory at least one week in advance. A *Collection Summary Form* must be completed and submitted to the Waring Laboratory by the depositor at least one week prior to delivery of the collection.

Preference will always be hand delivery. Prior approval will be required for delivery by mail. Appropriate measures must be made to ensure that material will not be broken during shipment, including additional wrapping of artifacts. All material delivered through the mail must be insured, certified, and sent via a Fine Art Shipper. Many shippers are available and information can be found at [www.icefat.org](http://www.icefat.org). The Waring Laboratory is not responsible for damage occurred during shipment.

It is acceptable to package the artifacts in extra boxes and packing materials just for transportation purposes. All extra boxes and/or packing material can be removed and returned following delivery to the Waring Laboratory.

## Footnoted References

- <sup>1</sup> Adelstein, P. Z., "Permanence of Digital Information," Access to Information Preservation Issues, Proceedings of XXXIV International Conference of the Round Table on Archives (Citra-1999), (Budapest: International Council on Archives, 1999) pp. 149-159.
- <sup>2</sup> Buck, Rebecca A., and Gilmore, Jean Allman, eds. *Museum Registration Methods*. 5th Edition. Washington, D.C.: AAM Press, 2010. Print.
- <sup>3</sup> Canadian Conservation Institute. 1995. *Storage of Metals*. CCI Notes 9/2.. 5 pp. Ottawa, Canadian Conservation Institute.
- <sup>4</sup> Childs, S. Terry and Eileen Corcoran 2000 *Managing Archeological Collections: Technical Assistance* ([www.cr.nps.gov/archeology/collections/](http://www.cr.nps.gov/archeology/collections/)). Washington, DC.: Archeology and Ethnography Program, National Park Service.
- <sup>5</sup> Freud, Leslie, Collections Manager, Phoebe Apperson Hearst Museum of Anthropology, University of California. May 2010. Personal Communication.
- <sup>6</sup> Gaylord Bros., Inc. *Guide to Collections Care*. New York: Gaylord Bros., 2007. Print.
- <sup>7</sup> Grisot, Suzanne and Marc Kodack. 1999. U.S. Army Corps of Engineers, St. Louis District. *Guidelines for the Field Collection of Archaeological Materials and Standard Operating Procedures for Curating Department of Defense Archaeological Collections*. Legacy Project No. 98-1714.
- <sup>8</sup> Melba Myers, Virginia State Repository, *How do I create a desiccated microclimate for storage?* [www.sha.org/rese/arch\\_resources/conservation\\_faqs/process.cfm](http://www.sha.org/rese/arch_resources/conservation_faqs/process.cfm), accessed 8/11/2010 (Accessed August 8, 2010)
- <sup>9</sup> National Park Service, 1993. "Use of Acryloid B-72 Lacquer for Labeling Museum Objects." *Conserve O Gram* 1/4. July 1993. 4 pages.
- <sup>10</sup> Northern States Conservation Center. *Collection Labeling Kit Instruction Booklet*. 1998. Print.
- <sup>11</sup> Registrars' Committee of the American Association of Museums. [rcaam@si-listserv.si.edu](mailto:rcaam@si-listserv.si.edu) or [www.rcaam.org](http://www.rcaam.org). Online posting.
- <sup>12</sup> Society for Historical Archaeology. *Initial Processing Of Archaeological Materials* [www.sha.org/research\\_resources/conservation\\_faqs/process.cfm](http://www.sha.org/research_resources/conservation_faqs/process.cfm)
- <sup>13</sup> Young, Holly, Curator of Collections Pueblo Grande Museum, Phoenix AZ. May 2010. Personal Communication.

# Reference Materials and Guidance

## 4. Curatorial Care of Archeological Objects

### From Appendix I of the National Park Service Museum Handbook

#### APPENDIX I: CURATORIAL CARE OF ARCHEOLOGICAL OBJECTS

##### A. Overview

1. *What is an archeological object?*

Archeological objects are the result or product of an activity in the past that has been recovered from an archeological site. Archeological objects may have originated in the ancient past or quite recently. Depending upon the soil and climate of the site, a wide variety of materials may be excavated.

• *Inorganic* artifacts include:

- metal
- ceramics
- glass
- stone

• *Organic* artifacts include:

- leather
- basketry
- textiles
- modern plastics and other synthetics
- bone
- teeth

Archeological collections may also contain non-artifactual samples, such as botanical material, soils, pollen, phytoliths, oxylate crystals, snails, insect remains, and parasites.

While some individual archeological objects are found in NPS collections, the majority have been recovered as part of systematic archeological excavation. Preservation and care of individual objects must also consider the impact on the collection as a whole.

An important part of archeological collections are the associated archival records (for example, field notes, photographs, maps, digital documentation). For information on managing and preserving these archival records see *Museum Handbook*, Part II (*MH-II*), Appendix D: Museum Archives and Manuscript Collections and *Museum Handbook*, Part I (*MH-I*), Appendix J: Care of Paper Objects, Appendix M: Management of Cellulose Nitrate and Cellulose Ester Film, and Appendix R: Curatorial Care of Photographic Collections.



2. *What does this appendix cover?*

This appendix provides guidance only on the care of objects excavated from the ground. For guidance on collections from marine excavations, consult an archeological objects conservator with experience in the treatment of waterlogged materials. See Chapter 3: Preservation: Getting Started, Chapter 8: Introduction to Museum Object Conservation Treatment, and Conserve O Grams 6/1-6/6 for more information.

This appendix does not cover field treatment of objects when first excavated. Good sources of information on this topic include Sease (1987) and Watkinson and Neal (1998) listed in the references.

3. *What makes archeological objects different from other materials commonly found in museum collections?*

What makes archeological objects different is that at some point they were lost or abandoned and buried underground or in water.

The condition of these objects depends entirely on their reaction with the environmental conditions to which they have been exposed through time. Underground the object reaches a kind of equilibrium with the surrounding soil. Then, when the object is excavated, it must adjust to a new and radically different environment. Reactions can involve both physical and chemical changes. Regardless of the condition of the object before excavation, the moment it becomes exposed it is vulnerable to rapid deterioration. Figure I.1 illustrates the deterioration rate of archeological objects through time.

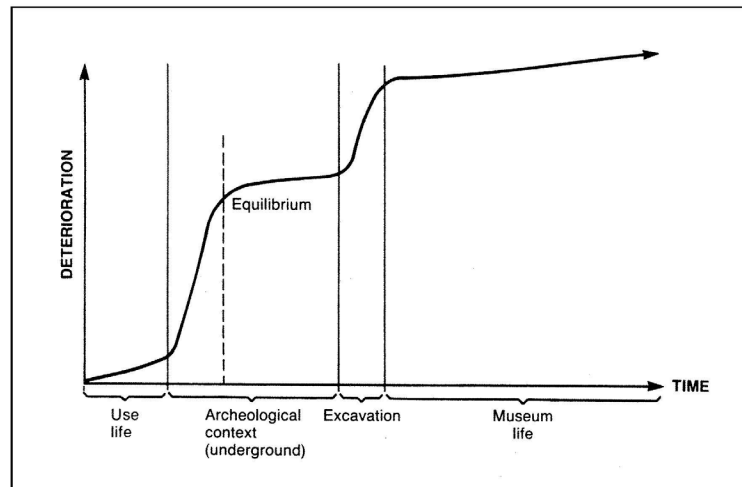

Figure I.1. Deterioration of Archeological Objects through Time

4. *How can I minimize deterioration of archeological objects?*

Preservation of archeological collections is a collaboration between archeologists, curatorial staff and conservators. Each person brings a different perspective and expertise to the problem. It is important to understand the concerns and needs of these other professionals when making decisions about how to care for archeological objects.

Preservation must begin in the field. Curatorial staff should work with archeologists depositing collections to make sure that preservation concerns are addressed during archeological procedures at the site and in the processing laboratory. Work with conservators both in the field and at the repository to ensure preservation choices are based on current research. Follow through with proper curatorial care in museum collections storage.

Refer to Director's Order #28 and Chapter 6: Management of Archeological Resources of the *Cultural Resources Management Guideline*, for guidance on the responsibilities of the archeologist before selecting a repository and depositing collections. See Director's Order #24, NPS Museum Collections Management, for park management's responsibility to ensure appropriate care and management of archeological collections.

---

## B. Handling and Cleaning of Archeological Objects

1. *How should I handle the objects?*

Because the research value of archeological material may be lessened or destroyed by unnecessary handling and inappropriate treatment, preservation of these materials should be based on preventive care. Careful handling, packaging, and storing of archeological objects are crucial for the survival of the material as an artifact. Mishandling and storage will encourage deterioration and can reduce the material to nothing more than powder.

Archeological objects can have a deceptive appearance of strength when first uncovered. All excavated materials have undergone some form of alteration during the equilibration process underground and during the recovery process. This alteration has physically weakened the object. While underground, objects are supported by the surrounding soil, and when excavated, they may be unable to support their own weight. For this reason, archeologists and conservators often use specialized lifting techniques to excavate fragile and potentially fragile objects. During and after excavation, continue to support these objects on a tray or pallet or in a container that distributes weight properly.

***An archeological object must always be fully supported. Use both hands, a tray, or a supporting container to lift and carry an object, whether it is large or small. Always assume that an excavated object is weak.***

Review the guidelines for handling museum objects in Chapter 6: Handling, Packing, and Shipping Museum Objects.

2. *How should I clean the artifacts in museum collections?*

Cleaning of archeological material should be kept to a minimum. The cleaning process may destroy important archeological evidence such as surface decorations and composite or associated materials that often exist only as impressions on the surface of the object or in the surrounding soil. Original surfaces of metal objects may lie within layers of corrosion. Evidence of use (for example, food residue in containers, pigment traces on stone palettes, or blood traces on stone projectile points) may be removed by unnecessary cleaning.

Cleaning may also interfere with scientific analysis. For example, the use of acid to remove deposits on ceramics may also remove acid-soluble compounds in the ceramic paste and as a result, invalidate compositional analysis used to determine the prehistoric source of clay. See *Conserve O Gram* 6/6, "Long-term Effects of Acid-Cleaning Archeological Ceramics." Water can also remove amino acid traces used to date bone. Washing may also hasten deterioration of salt-contaminated material and can be disastrous to metal objects if they are not carefully and completely dried afterward.

***Avoid any treatment that alters the chemical or physical integrity of the artifact. Don't risk losing valuable information or inflicting irreversible damage.***

Once an object has reached the repository and is in curatorial care, remove only loose dust and dirt by dry brushing or vacuuming. **Don't** wash the object and **don't** apply pressure. The surface of an archeological object is often fractured or friable and may be easily dislodged by rubbing. Carefully assess an object's surface **before** you start to clean it. If additional cleaning, stabilization, or repair is necessary, consult an experienced conservator.

---

## C. Storage Conditions for Archeological Objects

1. *How should I organize archeological collections in storage for best preservation?*

Archeological collections are often large and contain a variety of materials with different environmental storage requirements and with different research values. Physical organization of the collections by research values, such as source or cultural affiliation, will not necessarily meet preservation needs. It is better to organize the materials by environmental requirements and maintain the research integrity of the collection through good museum records.

Ideally, all archeological objects should be stored in climate-controlled areas, but this often is not practical. Most archeological collections are large and not all storage facilities have enough climate-controlled storage space to house entire collections. In such cases, it is possible to maximize preservation while minimizing utility costs by implementing a storage strategy based on the environmental requirements of various archeological materials.

# Guidebook for State-Owned Collections

2. *What are the environmental requirements?* See the chart below for a system to organize archeological material by environmental sensitivity.

<b>Organization of Archeological Material</b>	
<i>Level I: Negligibly climate-sensitive materials</i>	
<p><b>Materials:</b></p> <ul style="list-style-type: none"> <li>• stable stone and fired ceramics</li> <li>• stable inorganic architectural materials (plaster, mud, daub, brick, and stone)</li> <li>• dry pollen, flotation, and unprocessed soil samples</li> <li>• faunal remains</li> </ul>	<p><b>Required Climate:</b> Gradual daily and seasonal fluctuations of temperature and relative humidity can be tolerated.</p> <ul style="list-style-type: none"> <li>• <b>Relative Humidity:</b> Above 30% and below 65%. Mold may become a problem above 65%.</li> <li>• <b>Temperature:</b> Freezing to 100°F. Moderate and cool temperatures are preferred. High temperatures increase deterioration of all materials.</li> </ul>
<i>Level II: Climate-sensitive materials</i>	
<p><b>Materials:</b></p> <ul style="list-style-type: none"> <li>• stable metal</li> <li>• stable glass</li> <li>• worked bone, antler, and shell</li> <li>• botanical specimens</li> <li>• textiles</li> <li>• wood</li> <li>• skin, leather, and fur</li> <li>• feathers and horn</li> <li>• natural gums, resins, and lacquer</li> <li>• human remains</li> </ul>	<p><b>Required Climate:</b></p> <ul style="list-style-type: none"> <li>• <b>Relative Humidity:</b> Determine a stable point based on the object's environmental history and current regional climate. If the materials will be stored near the collection site, you may follow these guidelines.                             <ul style="list-style-type: none"> <li>30-40%--semi-arid areas and deserts</li> <li>40-50%--central and eastern plains and woodlands</li> <li>45-55%--seacoast and lakeshore</li> </ul> </li> <li>Keep conditions as stable as possible. Many organic materials are more sensitive to fluctuations of relative humidity than to any one unchanging level in the moderate range. Do not allow daily fluctuations of more than 3%. From summer to winter, keep the change to no more than a slow 10% drift.</li> <li>• <b>Temperature:</b> Above 50° F and below 75° F. You may adjust the temperature slightly to control the relative humidity, but do not exceed changes of 5° daily.</li> </ul>
<i>Level III: Significantly climate-sensitive materials</i>	
<p><b>Materials:</b></p> <ul style="list-style-type: none"> <li>• unstable (salt-contaminated) ceramics, stone, and bone</li> <li>• unstable glass (glass that appears damp or "weeping")</li> <li>• unstable metal, particularly iron</li> <li>• mummified human and animal remains</li> <li>• composite objects (objects made of several different materials)</li> </ul>	<p><b>Required Climate:</b></p> <ul style="list-style-type: none"> <li>• <b>Relative Humidity:</b> Keep the RH within the restricted range determined by the object's composition and condition. Follow these guidelines.                             <ul style="list-style-type: none"> <li>– metal—under 30%. Unstable iron is best stored below 15%.</li> <li>– unstable glass—30% to 40%</li> <li>– naturally mummified animal remains—15% to 20%</li> <li>– unstable ceramics, stone and bone (salt contaminated)—below 50% (<i>Note:</i> Keep the RH as steady as possible to avoid damage by the hydration cycling of soluble salts.)</li> </ul> </li> <li>• <b>Temperature:</b> Choose a point between 60° and 72° and keep the temperature steady. Allow it to fluctuate only enough to keep the RH in check.</li> </ul>



3. *What are the storage requirements for each of the three levels of climate sensitivity?*

Each level of climate sensitivity requires a different type of storage.

- **Level I:** General storage for Level I materials should meet the *minimum* overall standards for all NPS storage spaces as outlined in Chapter 7: Museum Collections Storage.

- Store materials that do not need special attention in boxes on open shelves.
- Store loose material, including the following, in bags within boxes:
  - bulk botanical specimens
  - unprocessed soil samples
  - dry pollen and flotation samples
  - slag
  - unworked bone
  - lithic cores and debitage
  - ceramic sherds

Make sure the bags are strong and will not tear or puncture. Bags made of Tyvek®, a strong spun polyethylene plastic that allows water vapor to escape, are a good choice. Canvas bags and resealable polyethylene bags can also be used.

- **Level II:** Climate-controlled storage for Level II materials should comply with the *optimum* standards for NPS storage areas as outlined in Chapter 7.

If your park has no currently available area where the environment can be controlled, consider putting up a prefabricated, climate-controlled structure. See *Conserve O Gram 47*, “Museum Collection Storage Space: Is an Insulated Modular Structure Right for your Collection?” Consult your regional or support office curator, conservators specializing in environmental or preventive conservation, or the Museum Management Program for guidance in developing an acceptable storage area.

- **Level III:** Microclimate storage for some Category III materials can be created within the climate-controlled storage area used for Category II materials.
  - Place objects requiring an extremely stable environment within a closed well-gasketed museum cabinet that will shield them from even slight fluctuations in relative humidity.
  - Place metals and unstable glass, which require a relative humidity quite different from other objects in storage, in tightly sealed boxes with moisture-sensitive materials called *sorbents*. Sorbents, such as *silica gel*, buffer the interior of the container against changes in the relative humidity of the enclosed objects.

## D. Storage Techniques for Archeological Collections

### 1. What type of storage container should I use to store archeological objects?

There are many different types of standard boxes and bags that are appropriate for general storage. **Note: These are not for microclimate storage.** See Chapter 4 for information on microclimate storage.

- Use acid-free boxes with lids rather than self-closing boxes with flaps that will wear out over time.
- Store small objects like lithic points and nails in boxes manufactured for the storage of archival and photographic collections.
- Use small resealable polyethylene bags for individual specimens and stack them vertically within each section of the box. You can stack them to acid-free index cards to make them easier to stack. If the objects are not numbered, include an acid-free tag with an identification number inside each bag and also be sure to write the number on the outside of the bag or on the card.

See Figure I.2. Note the easy visual access and consistent packaging technique illustrated. Never wrap objects in padding material. Wrapping and unwrapping requires excessive handling.

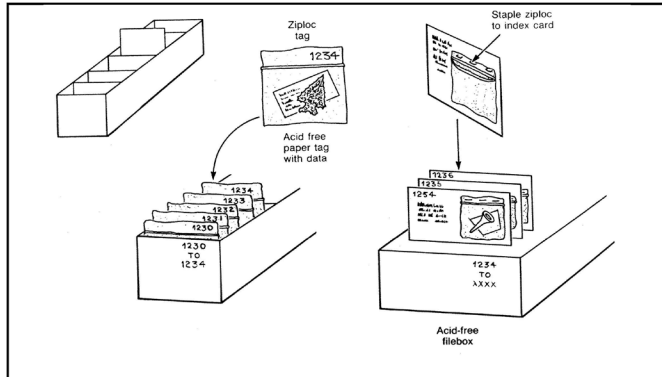

**Figure I.2. Vertical Stacking of Small Objects within Standard Containers**

2. *Why is silica gel often used in archeological storage?*

Archeological objects are often unstable and very sensitive to changes in relative humidity. Silica gel can moderate fluctuations in relative humidity within a closed container.

Silica gel is inert, amorphous silicon dioxide in a porous granular form that is able to adsorb moisture from the air. It can adsorb 30-40% of its dry weight and responds more quickly than other sorbents to variations in relative humidity. The gel rapidly senses, corrects, and stabilizes fluctuations in relative humidity by humidifying or dehumidifying the air around it to maintain its own preferred environment. See Chapter 4: Museum Collections Environment, for information on use of silica gel in microclimates.

3. *How should I cushion my objects?*

Use padding material to prevent the contents of a container from shifting when it is moved. Be careful not to overstuff the box with crumpled tissue or other padding material that could exert damaging pressure on fragile objects. Use either of these cushioning techniques:

- Make smooth pillows to place against the surface of the object by folding wadded acid-free *unbuffered* tissue paper within loose rolls of tissue. Wrapping the crumpled tissue will keep it from expanding and exerting pressure.
- Fill resealable sandwich-sized polyethylene bags with cotton.

***Don't use cotton or polyester wool alone. Cotton is an excellent sorbent and may hold moisture directly against the object. Fibers from these materials may snag and damage delicate artifacts.***

4. *How should I organize the box contents?*

Organize your artifacts so that each object can be easily retrieved without disturbing the rest. One technique is to layer your items. If they are small and lightweight, they can be organized into three or four layers separated by specimen trays within your storage box. Specimen trays make lifting safer. Cushion each layer with a sheet of stable polyethylene foam shelf liner. See Figure I.3. Museum supply companies manufacture acid-free boxes with fitted trays equipped with adjustable interior compartments. These are ideal for the storage of archeological material.

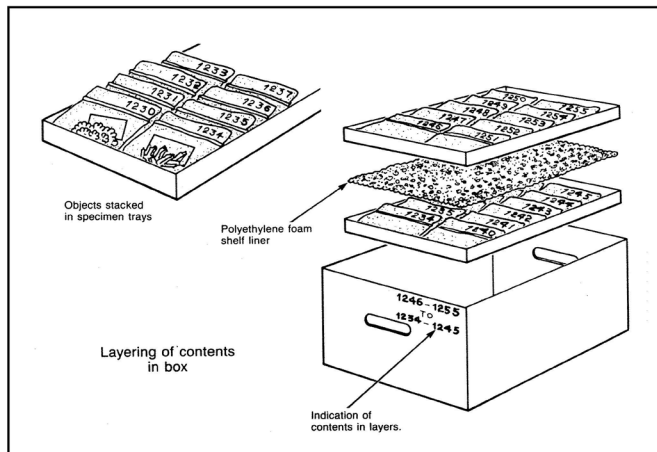

**Figure I.3. Organization and Layering of Objects within a Storage Box**

5. *How do I keep track of what's in the box?*

Make an inventory:

- First, make sure that the identification numbers you have written on each bag show clearly.
- Next, label the outside of the box with the numbers by layer.
- Prepare a more detailed list of the contents and place it in the box on top of the contents.

6. *How do I protect and store larger archeological objects?*

If the objects are too large for standard specimen trays, you can make custom trays from padded, acid-free board fitted with cotton twill-tape handles. See Figure I.4 for an illustration. There are many acid-free boards, including matboard, cardboard, foamboard, and honeycomb board, that can be used to make support trays. Make sure you select a board heavy enough not to bend under the weight of the object. Tie the object to the tray with cotton twill tape to keep it from sliding.

Use rigid polyethylene foam to make tray supports and trays with cavities for fragile three-dimensional objects. You can easily cut large blocks of foam with an electric carving knife and thin sheets with a sharp X-acto knife. Figure I.5 illustrates the use of rigid polyethylene foam blocks to support a fragile bottle. Figure I.6 shows the cavity-packing technique to restrict the movement of smaller, rounded items. Cavity-packing is an excellent way to store objects that are moved periodically for research. Make sure that the fit of the object in the cavity is not too tight and that the object may be safely removed from the tray. The cut edge of the rigid foam block can be abrasive so use thin, soft, polyethylene foam (like Volara®) for objects with fragile surfaces. If necessary, carve a finger grip on each side of the object to make grasping easier.

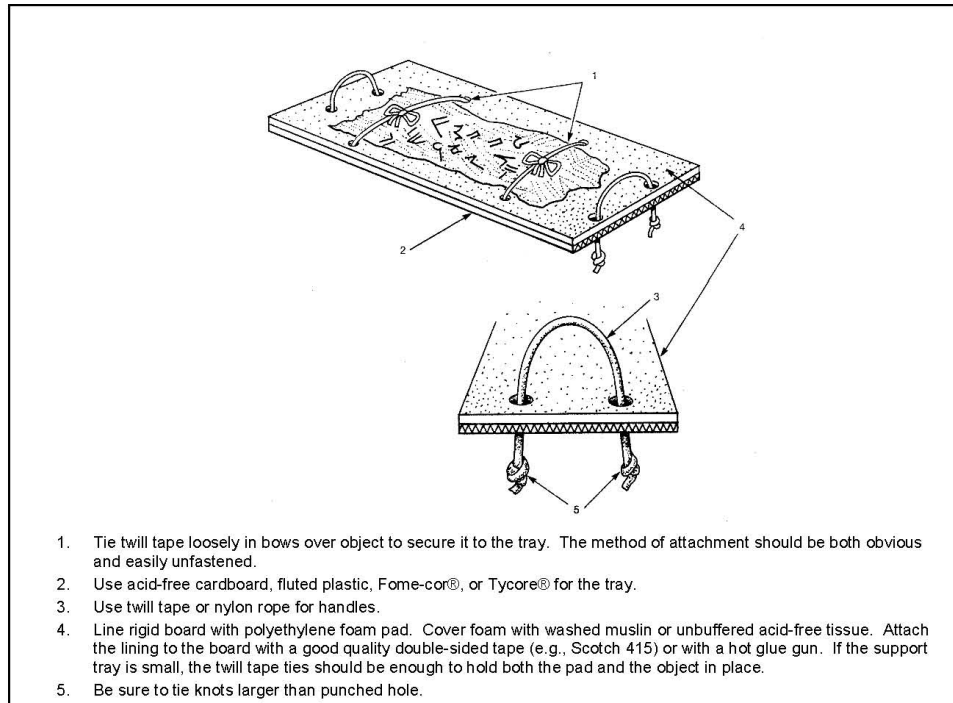

**Figure I.4. A Support Tray for Fragile Material**

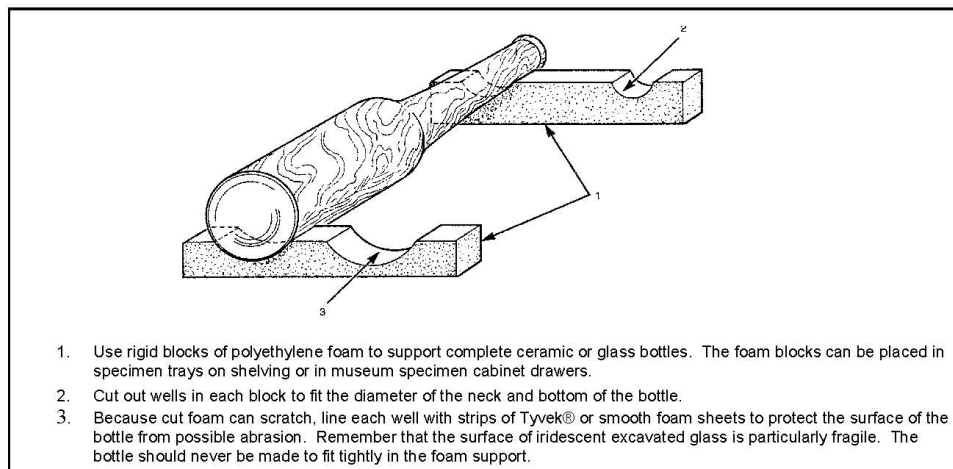

**Figure I.5. Customized Support Blocks for a Fragile Glass Bottle to be Fitted in a Museum Specimen Tray**

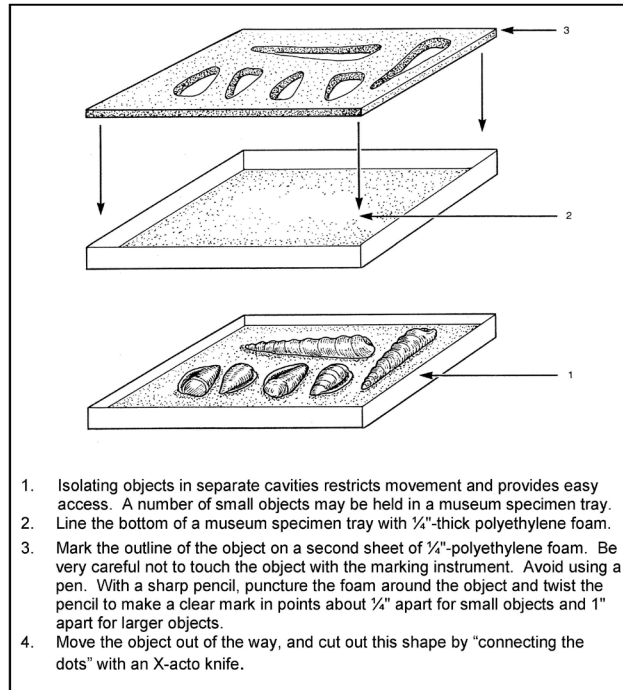

1. Isolating objects in separate cavities restricts movement and provides easy access. A number of small objects may be held in a museum specimen tray.
2. Line the bottom of a museum specimen tray with  $\frac{1}{4}$ "-thick polyethylene foam.
3. Mark the outline of the object on a second sheet of  $\frac{1}{4}$ "-polyethylene foam. Be very careful not to touch the object with the marking instrument. Avoid using a pen. With a sharp pencil, puncture the foam around the object and twist the pencil to make a clear mark in points about  $\frac{1}{4}$ " apart for small objects and 1" apart for larger objects.
4. Move the object out of the way, and cut out this shape by "connecting the dots" with an X-acto knife.

**Figure I.6. Cavity Packing Technique for Small Objects**

7. *How should I store very weak and fragile objects?*

Archeological objects that are weak from deterioration may require specialized supports to maintain their structural integrity. Before designing a special mount, evaluate the object's strong and weak structural points. Determine:

- what the object is
- how it was used or worn
- how it was made

For example, cone-shaped baskets, worn like backpacks, were used to carry heavy objects. Load stresses were distributed down the sides of the basket and concentrated in the bottom. Though the rim is the weakest part of these baskets, they are frequently, but incorrectly, stored upside down like traffic cones.

A good storage mount takes into account the *form* and *function* of the object and eliminates stress on the weakest parts. A cradle mount like the one illustrated in Figure I.7 will evenly distribute the weight of an object with an unstable base while keeping it upright as originally used.

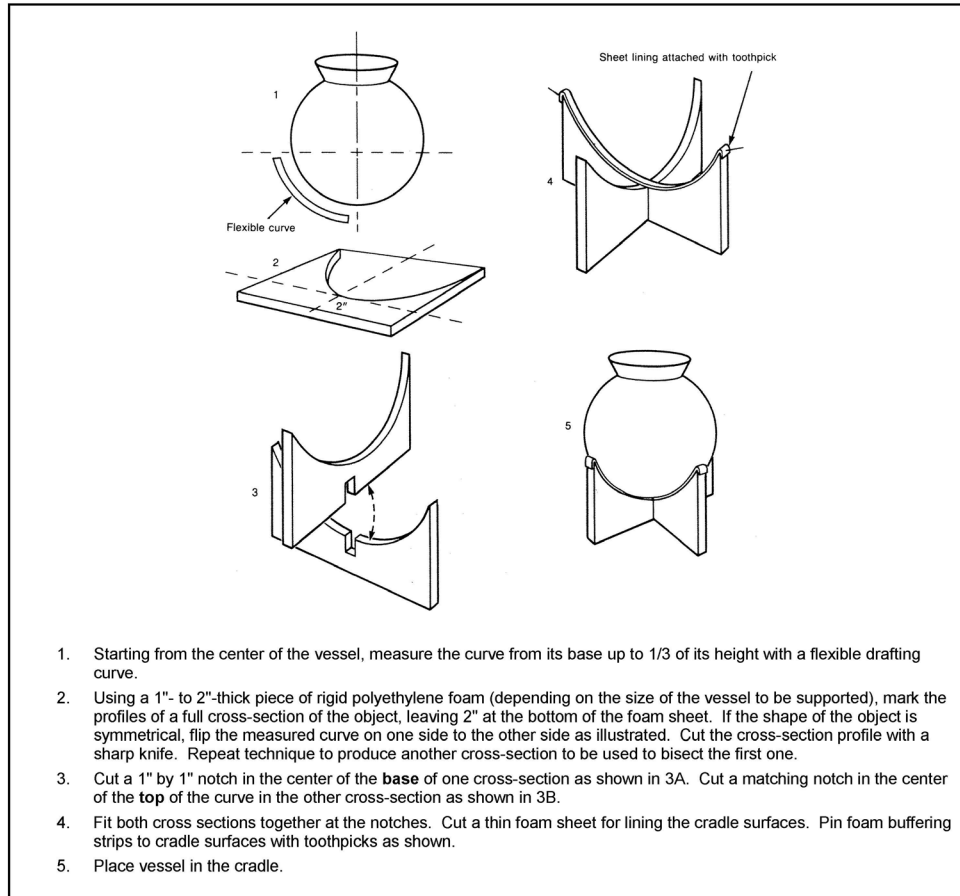

1. Starting from the center of the vessel, measure the curve from its base up to 1/3 of its height with a flexible drafting curve.
2. Using a 1"- to 2"-thick piece of rigid polyethylene foam (depending on the size of the vessel to be supported), mark the profiles of a full cross-section of the object, leaving 2" at the bottom of the foam sheet. If the shape of the object is symmetrical, flip the measured curve on one side to the other side as illustrated. Cut the cross-section profile with a sharp knife. Repeat technique to produce another cross-section to be used to bisect the first one.
3. Cut a 1" by 1" notch in the center of the **base** of one cross-section as shown in 3A. Cut a matching notch in the center of the **top** of the curve in the other cross-section as shown in 3B.
4. Fit both cross sections together at the notches. Cut a thin foam sheet for lining the cradle surfaces. Pin foam buffering strips to cradle surfaces with toothpicks as shown.
5. Place vessel in the cradle.

**Figure I.7. Construction of a Cradle Mount for Objects with Round Bases**



# Guidebook for State-Owned Collections

---

8. *How and when should I design special containers?*

When making a special box or storage container for an archeological object, keep these things in mind.

- Protect the object from dust and light.
- Provide it with good support.
- Allow researchers maximum visual access.
- Discourage any handling of the object.

In the case of a textile fragment, for example, a researcher will want to examine both sides. The container must permit close examination of the contents, but minimize the need to actually handle the object. A portfolio mount, illustrated in Figure I.8, is a good solution to this problem. This technique can also be used to store other flat objects like basketry fragments, thick cordage, and other fragile materials. Adjust the thickness of the interior mat to accommodate the dimensions of the object, avoiding any unsafe pressure or crushing of brittle elements.

Boxes for other types of artifacts should have a drop front so that the tray supporting the item can be slid out onto a stable surface. An accident is more likely to happen if the object must be lifted up and out through the top.

You may need to provide special containers and mounts that will protect fragile, unstable, and top-heavy objects during an earthquake.

There is much published information containing instructions for building specialized storage mounts. Two very good references are *Storage of Natural History Collections: Ideas and Practical Solutions* (Rose and de Torres, 1995) and *Working with Polyethylene Foam and Fluted Plastic Sheet* (Schlichting, 1994).

To help you select stable materials for constructing containers and mounts for storage see *Materials for Exhibit, Storage, and Transportation and Packing* (Tétreault and Williams, 1992) and “Guidelines for Selecting Materials for Exhibit, Storage, and Transportation” by Jean Tétreault, available on the Web at [http://www.cci-iic.gc.ca/frameset\\_e.shtml](http://www.cci-iic.gc.ca/frameset_e.shtml) under Conservation Information.

9. *How should I store items subject to the Native American Graves Protection and Repatriation Act of 1990 (NAGPRA)?*

Your park’s archeology collection may contain NAGPRA-related items such as human remains, associated funerary objects, unassociated funerary objects, sacred objects, and objects of cultural patrimony. These collections should be housed and handled with great sensitivity. You may need to store NAGPRA items separately from other collections and limit access to them.

Consult with the lineal descendants, culturally affiliated Indian tribes, Native Alaskan villages or corporations, or Native Hawaiian organizations to ascertain their preferences related to storage techniques and materials. You may need to use alternative storage methods and materials in response to these consultations. See Chapter 7: Museum Collections Storage, for additional information concerning consultation and storage of NAGPRA collections.



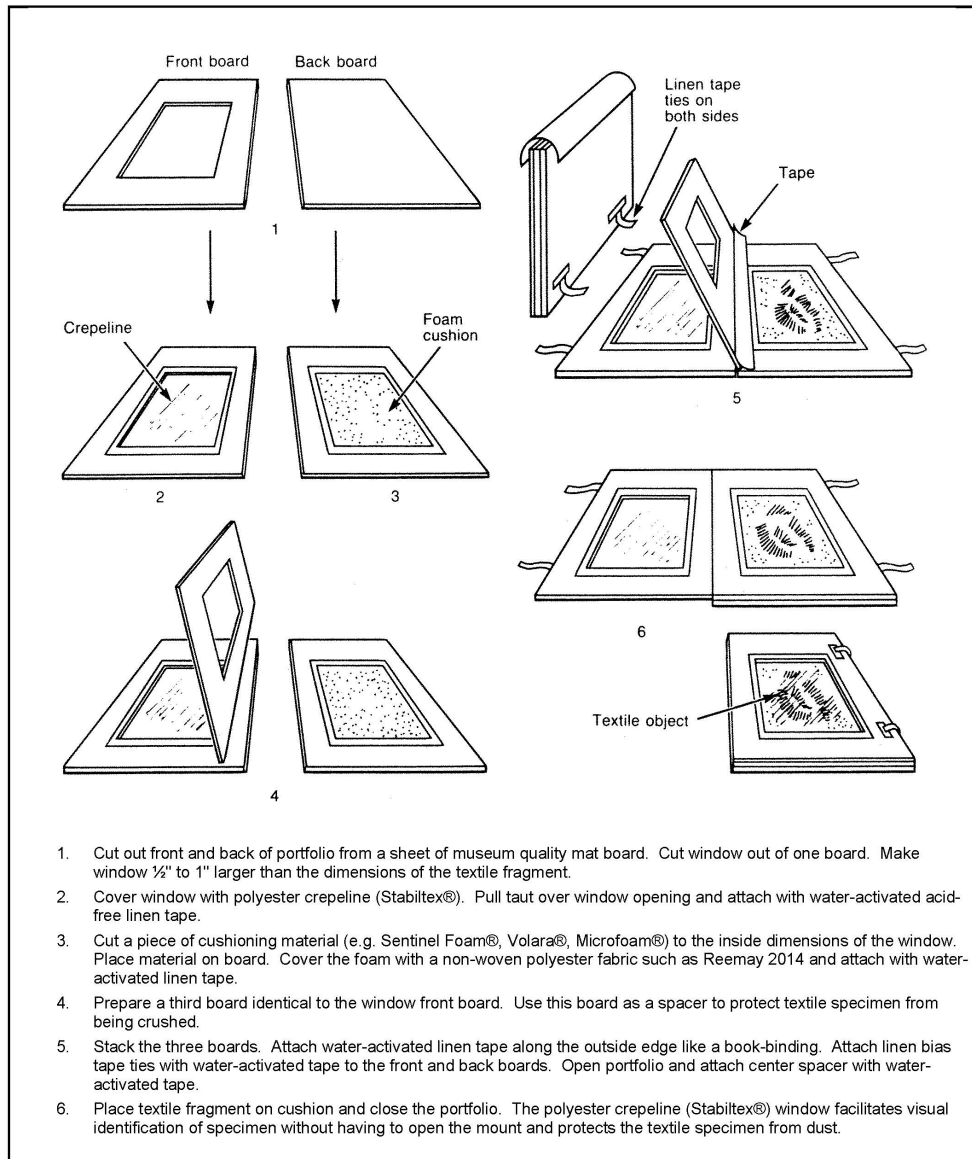

**Figure I.8. Construction of a Portfolio Mount for Archeological Textile Fragments**

# Guidebook for State-Owned Collections

---

<b>Recommended Storage Materials</b>	
<b>Bags</b>	
<b>Use:</b>	<b>Don't Use:</b>
<ul style="list-style-type: none"> <li>• Resealable polyethylene bags (Ziploc®, Baggies®, Whirl-pak®)</li> <li>• Spun polyethylene bags (Tyvek®)</li> <li>• Bags made from heat-sealable clear plastic laminate film</li> </ul>	<ul style="list-style-type: none"> <li>• Kraft lunch bags</li> <li>• Waxed paper</li> <li>• Envelopes</li> </ul> <p>None allow visual inspection and all are made from unstable materials. Waxed paper may leave a coating on the object.</p>
<b>Padding</b>	
<b>Use:</b>	<b>Don't Use:</b>
<ul style="list-style-type: none"> <li>• Acid free tissue</li> <li>• Cotton or polyester batting in plastic or muslin bags</li> <li>• Polyester felt</li> <li>• Bubble-pak or air-cap</li> </ul>	<ul style="list-style-type: none"> <li>• Loose cotton</li> </ul> <p>Brittle materials may snag on the loose fibers. Cotton will almost certainly leave lint on the objects.</p> <ul style="list-style-type: none"> <li>• Paper towels or facial or toilet tissue</li> </ul> <p>Papers are not durable and contain impurities.</p> <ul style="list-style-type: none"> <li>• Newspaper</li> </ul> <p>Newsprint smears easily and may leave ink on objects. Newspaper is also very acidic.</p> <ul style="list-style-type: none"> <li>• Excelsior</li> </ul> <p>Material is very acidic.</p> <ul style="list-style-type: none"> <li>• Vermiculite</li> </ul> <p>Substance generates dust that not only is difficult to remove, but also hazardous to museum workers</p>

**Figure I.9. Recommended Storage Materials**

# Guidebook for State-Owned Collections

<b>Plastic Foams</b>	
<b>Use:</b>	<b>Don't Use:</b>
<ul style="list-style-type: none"> <li>• <b>White</b> polyethylene closed-cell foam (Polyfoam)</li>   <li>• Crosslinked polyethylene foam (Plastazote®, Volara®)</li>   <li>• Ethylene/vinyl acetate copolymers (Evazote®, Volara®)</li>   <li>• Extruded plank polystyrene (Styrofoam)</li>   <li>• Polypropylene closed-cell foam (Microfoam)</li> </ul>	<ul style="list-style-type: none"> <li>• Blue polyethylene foam (fire retardant) Fire retardant additives can migrate to materials.</li>   <li>• Pink polyethylene foam (antistatic) Conductor in foam absorbs water from the air and can become soapy.</li>   <li>• Chlorinated or nitrated plastic (for example, PVC–polyvinyl chloride) Plastic outgases hydrogen chloride, which can become hydrochloric acid.</li>   <li>• Polyurethane This is unstable and may offgas harmful products.</li> </ul>

<b>Clear Plastic Sheets</b>	
<b>Use:</b>	<b>Don't Use:</b>
<ul style="list-style-type: none"> <li>• Polyethylene terephthalate clear polyester (Mylar®)</li>   <li>• Clear polyester and fluorocarbon laminate (Film-O-Wrap®)</li>   <li>• Clear polyester/polyolefin laminate (Scotchpak®)</li> </ul>	<ul style="list-style-type: none"> <li>• Polyvinylidene chloride (for example, Saranwrap®) PVC is unstable, chlorinated plastic.</li>   <li>• Cellophane Sulphuric acid used in manufacturing process generates acidic by-products.</li> </ul>

**Figure I.9 Recommended Storage Materials (continued)**

# Guidebook for State-Owned Collections

---

<b>Boards</b>	
<b>Use</b>	<b>Don't Use</b>
<ul style="list-style-type: none"> <li>• Acid-free mat board</li> <li>• Acid-free corrugated board</li> <li>• Acid-free Fome-Cor® (International Paper Co.); extruded polystyrene with polystyrene skin</li> <li>• Honeycomb boards                             <ul style="list-style-type: none"> <li>– acid-free rigid paperboard (Tycore®)</li> <li>– aluminum-board (Hexcel Honeycomb®)</li> </ul> </li> <li>• Corrugated polypropylene boards (Cor-X®, Coroplast®)</li> <li>• Double-walled polycarbonate (Lexan®)</li> </ul>	<ul style="list-style-type: none"> <li>• Regular cardboard or matboard</li> </ul> <p style="margin-left: 20px;">Non-archival cardboard and matboard are acidic.</p> <ul style="list-style-type: none"> <li>• Urea formaldehyde impregnated paper laminated panel board (Gatorfoam®)</li> </ul>
<b>Tape/Ties</b>	
<b>Use</b>	<b>Don't Use</b>
<ul style="list-style-type: none"> <li>• Water-activated paper or linen tape</li> <li>• Cotton or polyester twill tape</li> </ul>	<ul style="list-style-type: none"> <li>• Pressure sensitive tapes, including:                             <ul style="list-style-type: none"> <li>– cellophane</li> <li>– masking</li> <li>– strapping</li> <li>– duct</li> <li>– electrical</li> </ul> </li> </ul> <p style="margin-left: 20px;">The adhesive degrades and the carrier peels off leaving residues and stains.</p> <ul style="list-style-type: none"> <li>• Rubber bands</li> </ul> <p style="margin-left: 20px;">Rubber degrades and sticks to the surface.</p>

**Figure I.9. Recommended Storage Materials (continued)**

# Guidebook for State-Owned Collections

---

Fabric	
Use	Don't Use
<ul style="list-style-type: none"><li>• Polyester Stabiltex</li><li>• Reemay 2014</li><li>• Washed muslin</li></ul>	<ul style="list-style-type: none"><li>• Wool fabric</li><li>• Unwashed muslin</li></ul> <p>Sizing may attract pests.</p>

Figure I.9. Recommended Storage Materials (continued)

# Reference Materials and Guidance

## 5. Packing Museum Objects for Museum Shipment

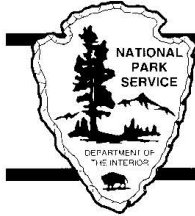

# Conserve O Gram

July 1993

Number 17/2

### Packing Museum Objects For Shipment

Packing museum objects for shipping can present a challenge. Imagining what can happen to an 800-year-old Anasazi corrugated jar during shipment is frightening. With proper preparation and planning, however, museum objects can be shipped safely and securely.

The following procedures and techniques are based on the experience of Mesa Verde National Park's curatorial staff in packing artifacts for a traveling exhibit, *Gustaf Nordenskiold, Pioneer Archeologist of Mesa Verde*. The exhibit was displayed at the park before traveling to five museums. The majority of the 200 objects were archeological and included sandals, baskets, bone implements, stone tools, pottery, and fiber bundles.

Packing techniques that mitigated the following two concerns were employed: minimum handling of the objects, and simplified unpacking and repacking of the objects by the five museums involved. A packing method known as "package-within-a-package" was used: cavity-packed objects are placed in cardboard boxes; cardboard boxes are then floated within an outer protective shipping crate that provides a safe, stable environment. This *Conserve O Gram* discusses cavity packing and preparation of the boxes. *Conserve O Gram 17/3* describes construction and packing of the crate.

Keep in mind a few basic considerations during the packing process: objects must be properly supported at the strongest points; objects must be protected against the effect of temperature and relative humidity changes and against vibration caused by transporting; and objects must be properly spaced within the box to avoid potential damage caused by crowding.

#### Preparation

Planning and preparation must precede the packing of museum objects. (See *Conserve O Gram 17/1*.) It is necessary to inspect and document object condition, select a safe method of shipment, prepare a work space, acquire materials, and observe rules for safe object handling. See *NPS Museum Handbook, Part I (Rev 9/90)*, Chapter 6, for guidelines on each of these procedures.

At Mesa Verde National Park, the Nordenskiold exhibit was displayed in a building separate from the museum collection work space, making it more practical to pack objects in the exhibit space after the exhibit closed. To minimize the amount of dirt and dust, the boxes and crates were constructed and the Ethafoam<sup>®</sup> was cut beforehand in a separate space from the exhibit area.

One point cannot be overemphasized: *allow sufficient time to pack the objects without being hurried and without interfering with other work activities*. The amount of time required to safely pack an object for shipment can be hours or, in some instances, days.

#### The Corrugated Box

Assembling boxes in which the objects are to be cavity packed is the next step in preparing objects for shipment. Boxes can be either purchased or custom-made. On the one hand, purchasing appropriate size boxes can save valuable staff time. On the other hand, constructing boxes permits customizing them to the dimensions and packaging needs of the objects.

Acid-free corrugated cardboard, both 2- and 4-ply, was used to construct the boxes. It is not absolutely necessary that acid-free cardboard be used. Cost may preclude using acid-free materials. However, using these materials shows that special care was taken during the initial packing of objects and encourages similar care by the receiving museum. In this case, 2-ply corrugated cardboard was used to construct boxes containing small, lightweight objects (e.g., bone awls, stone points, sandals), while 4-ply corrugated cardboard was used for heavier objects that required additional strength and for fragile objects that needed additional protection (e.g., pottery, stone axes, baskets).

The following procedures may be used to determine the size of the boxes needed to pack museum objects for shipment. The procedures apply either for purchasing ready-made boxes or for estimating the amount of cardboard that will be needed for custom-made boxes:

1. Obtain the dimensions of the objects. Photographs of the objects that include dimensions can be helpful, but seeing and examining the objects are important.
2. To these dimensions, add a minimum of two inches on every side as well as top and bottom between object and box for the cavity packing material. When packing multiple objects per box, include space between objects for packing material. Objects of similar material can be grouped together in a box when properly spaced. A listing of the objects grouped according to size within the material type can also be a help in estimating box sizes.
3. When standard boxes are used, obtain the sizes that closely fit the dimensions calculated in step 2 above. It is better to use a box that is a little too large than too small.
4. A two-piece custom-made box consisting of a bottom and separate lid can be constructed as follows:

- Use a mat knife (e.g., an X-Acto knife) and metal ruler to cut corrugated cardboard. Place the ruler, which is used as a cutting guide, along the line to be cut. First score the cardboard along the line, then make additional cuts until all layers of the cardboard have been cut. Change the knife blade frequently to maintain a sharp edge for clean cuts.
- Cut and construct the bottom before making the lid to ensure a snug fit as shown. Score (without cutting) the cardboard along the line to be folded. Tape the corners with fiber tape or reinforced strapping tape. Make a pattern or template to follow before cutting.

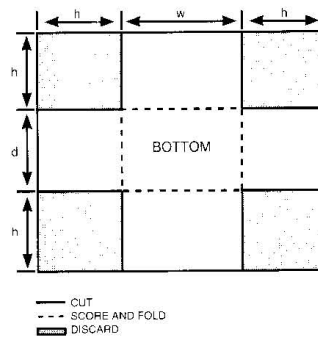

- To make the lid to fit the width and depth of the bottom, place the bottom of the box on a sheet of corrugated cardboard and trace the outline. Allow two inches on each side to form a lip for the lid.
- Score the cardboard along the line to be folded to make the lip. Tape the corners with fiber tape or reinforced strapping tape.

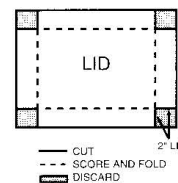



## Cavity Packing for Boxes

Cavity packing involves placing an object in successive layers of material (e.g., polyethylene foam) into which an opening is cut. The packing material insulates the object and will absorb vibrations created during shipping. Cavity packing supports the object and cushions it from movement. It also creates a micro-environment for the objects.

Polyethylene foam (e.g., Ethafoam) can be used to cavity-pack many solid, stable, three-dimensional objects. It is also good for very heavy objects. For more vulnerable objects, such as ceramics or glass, a softer urethane ester-type foam may be preferred.

Ethafoam is available in various densities and comes in sheets 4 feet wide by 8 feet long, with thicknesses varying from 1/2 to 4 inches. The 2- and 3-inch-thick foam was the most useful for this traveling exhibition. Both the 3- and 4-inch-thick Ethafoam can be more difficult to cut by hand and it may be necessary to use an electric saber saw. A sharp, long-blade utility knife, a serrated bread knife, or an electric slicing knife can also be used for cutting. The steps to fabricate cavity packing are as follows:

1. To begin cavity packing, cut the layers of foam to fit the length and width of the box. The number of layers will depend on the depth of the box and thickness of the foam.
2. Take the piece(s) of foam to be carved for the cavity and draw an outline of the object on the foam. Place the object directly on the foam, outlining *carefully* with a No. 2 pencil. Take care not to mark the object. Size the cavity so that the object is held firmly in place yet can be removed without abrasion or damage.
3. A horizontal cut can be made into the side of the foam under the object's outline and at a depth equal to the thickness of the object. Next a cut is made following the object outline down to the horizontal cut. Remove

the foam cutout. If more than one object is packed in a box, label each cavity to that specific object.

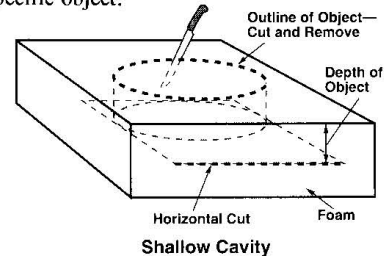

4. Allow enough room so that the object can be wrapped with acid-free tissue before being placed in the cavity or that the cavity can be lined with tissue and then folded over the object without crushing it. The tissue prevents abrasion and the loss of fragments dislodged during transportation and also aids in removal of the item from the cavity. When the cavity is lined with tissue, it remains in place while only the object is removed.
5. For shallow cavities, a 1/4-inch-wide strip of cotton bias tape can be placed under the object so that the ends of the tape can be grasped in order to gently pull the object out of the cavity.
6. When cutting a deeper, multi-layer cavity, each layer must conform to the shape of the objects at that level. Fill in excess space with acid-free tissue. Number the layers using felt tip marker so that they are repacked in the same order.

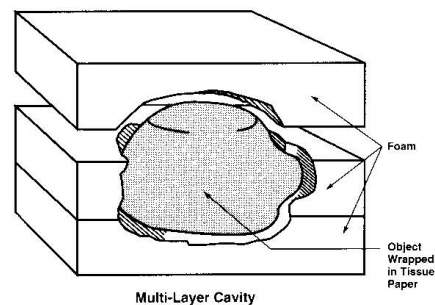



7. After the object is placed in the cavity, add the top layer of foam to completely fill the box and prevent any movement.
8. Secure the lid to the box with adhesive tape or tie it with cotton bias tape.
9. On the exterior of the box lid, list the catalog numbers for all objects in the box as well as the exhibit number, the object box number, and the number of the crate into which it will be packed. Either on the exterior or interior of the box lid, note any instructions for special handling, for unpacking, or for repacking the box. Include photographs or photocopies of the objects that are contained in the box.

The above method for packing objects will minimize the hazards that objects are subject to during travel. Used successfully by Mesa Verde National Park, it is one of several ways to safely pack objects for shipping. Consult the NPS *Museum Handbook*, Part I (Rev 9/90), Chapter 6, for alternative methods that may suit a particular situation. Procedures and techniques for packing ceramics, glass, and stone are discussed in the NPS *Museum Handbook*, Part I, Appendix P. Where there are special concerns regarding the packing of a specific object, consult a conservator before proceeding.

## *Sources*

The supplies necessary for packing objects can be obtained through a packaging supplier, or consult the NPS *Tools of the Trade* for names of vendors for specific materials. **NOTE:** When ordering supplies that will be used for object packaging, emphasize that supplies must arrive clean. This is especially important when ordering polyethylene foam (Ethafaom). Also consider where packing materials will be stored until used. Because foam and paper products absorb moisture, they should be stored in a space that provides control of relative humidity levels.

Standard size, corrugated boxes can be purchased by parks and other government agencies from General Services Administration (GSA). They also are available from local packaging suppliers.

Elizabeth Bauer  
Curator  
Mesa Verde National Park  
National Park Service  
Mesa Verde National Park, Colorado 81330

---

The *Conserve O Gram* series is published as a reference on collections management and curatorial issues. Mention of a product, a manufacturer, or a supplier by name in this publication does not constitute an endorsement of that product or supplier by the National Park Service. Sources named are not all inclusive. It is suggested that readers also seek alternative product and vendor information in order to assess the full range of available supplies and equipment.

The series is distributed to all NPS units and is available to non-NPS institutions and interested individuals by subscription through the Superintendent of Documents, U.S. Government Printing Office, Washington, D.C. 20402, FAX (202) 512-2233. For further information and guidance concerning any of the topics or procedures addressed in the series, contact the National Park Service, Curatorial Services Division, Harpers Ferry, WV 25425, (304) 535-6410.

## Reference Materials and Guidance

### 6. Helpful Notes on Smaller Exhibits by Nicholas Dungey,

Edited by Alaura Hopper

#### Plan Big:

- Start with big ideas for an exhibit! Specifically revolving around a theme or themes that will be narrowed down to one theme over time.

#### More than just the exhibit:

- While the small exhibit may only be in one display case, there can be extensions such as exhibit text on a wall, placing an informative stanchion next to the exhibit, or including brochures for visitors to use after interacting with the exhibit

#### Interaction:

- Can the exhibit be interactive? Do you have volunteers or workers who can do this? If it's possible, then an interactive exhibit may be more productive and produce higher visitor count
- Having a volunteer or worker providing extended information for even an hour a day can create more visitor output to a smaller exhibit
- Technology and quick, fun surveys aren't bad either – have this on a nearby table or a cork board where people can pin what they write, these ideas get visitors involved and make it more interesting for them

#### Design:

- Eye-catching
- Eye-catching, again (it's that important); a small exhibit is just that: small. Because of this, you will evidently have less to work with than a full exhibit and less to lead up to this exhibit; for that reason, you will want to have something eye-catching about your exhibit that has the ability to stop the visitor and 'catch' their attention, this can include, but is not limited to:
  - Descriptive visuals
  - Catchy title
  - Interesting artifacts (something that many people may have not seen)
  - Colorful text or displays
  - Bigger text with relevant/thought-provoking information
  - Maps (visitors love maps)
    - Note: this is coming from experience on a smaller exhibit I worked on; while it had interesting artifacts, the surrounding colors were pretty dull compared to many colorful or eye-catching exhibits. I didn't receive a visitor count for it, but I assume it may have been low

#### Change:

- Since these are smaller exhibits, they can be changed more often than a full exhibit, providing volunteers, new workers, interns, or students exhibit experience and the ability to share their exhibit ideas and designs with the world
- "Variety is the spice of life!" Having this variety will bring back more visitors and can provide something eye-opening, -popping, or -catching, possibly having the ability to bring in more visitors to a museum, repository, government building, library, or any other building willing to showcase a small exhibit

# Guidebook for State-Owned Collections

---

## Location:

- Location, location, location!
- Make sure the small exhibit is in a high-traffic location – putting it in front of offices only accessed by office workers will make it a low-traffic location where many of the public will be unable to see it
- Place it at an entryway where people leaving or entering a building can interact with the exhibit on their own time; or in a more high-traffic area, such as a lobby, to encourage further visitor output

## Informative:

- However you look at it, museums, repositories, governments, or libraries have opinions. By all of these entities have biases – political or otherwise; they have a voice!
- make use of that voice
- Have your exhibit be informative and fit with the mission of your entity – even if it is ‘small’ it still has the ability to leave a lasting impact on visitors that may provoke further learning on the exhibit topic or exploration of the entity showcasing the small exhibit
- If relevant, you can even use it as a small extension of a featured exhibit to be used as an example of what one can see at the full exhibit

## Brief:

- Get your point across
- Make your text succinct and to the point; don’t provide information that can be easily researched by visitors, but rather provide information that can lead them to do further research, generate that interest!
- Visuals can provide that brief expression in an eye-catching way that uses up more space, but less wordy. Less words does not necessarily mean better, but people will prefer a brief to the point presentation that takes 5-10 minutes rather than a report that provides a lot of information, but takes 30 minutes to read and is mostly forgotten by visitors by the time they move on.

## Security and environmental control:

- Have strong security, whether this exhibit be under a glass exhibit case or behind a locked cabinet case, the objects in this exhibit need to be protected and, if possible, under surveillance
- Another thing to consider is environment control – will the objects used in this exhibit (if there are objects) be affected by the surrounding environment? UV light? Fluorescent lighting? Oxidization? Mold? Pests? Fire? People? Where are these objects stored and can they be protected under emergency circumstances? Coming up with a brief emergency preparedness and environmental monitoring plan for this display case can provide ease of mind to the entity

## Documentation:

- Draft up some internal loan forms and condition forms, let the rest of the entity know where the objects in this small exhibit are being held – after all YOU may know, but an Intern may be conducting a brief inventory and involuntarily panic because one of the more expensive objects in the collection is “missing” when in actuality it is upstairs in a case they haven’t seen yet – for the sake of sanity and lack of panic. Ake sure to keep documentation of where the artifacts are.

## Collaboration:

- Work with other entities, create some collaboration to create contacts and ties, support other entities and do the same – it might lead to something even better down the line; start small, continue big!

## Other Resources

- “Keep it small, stupid!” is a tag line in museums that is known pretty well, but an example of this by Nick Sacco for the National Park Service’s 100<sup>th</sup> birthday can be found [here](#)
- Pop Museums/Exhibits provide the opportunity to make changes to full exhibits, create public relations, and do evaluation and market research, while taking up little space and resources – steps to creating an exhibit like this can be found [here](#)

## Collections Management References

### 1. Collections Management Guides:

James B. Gardner and Elizabeth E. Merritt 2004 *The AAM Guide to Collections Planning*. American Association of Museum Professional Education Series, Washington DC

Fahy, Anne (editor) 1995. *Collections Management* Leicester Readers in Museum Studies Routledge New York

### 2. Registration:

Buck, Rebecca A. and Allman Gilmore (editors) 2010 *The New Museum Registration Methods*. American Association of Museum Professional Education Series, Washington DC

## Collections Management References

### 3. Web Resources

#### 3a. Archaeological Collections Care and Management

National Park Service Museum Management Program:

<https://www.nps.gov/museum/>

National Park Service Museum Handbook:

<https://www.nps.gov/museum/publications/handbook.html>

National Park Service Conserve O Grams:

[https://www.nps.gov/museum/publications/consveogram/cons\\_toc.html](https://www.nps.gov/museum/publications/consveogram/cons_toc.html)

National Park Service Distance Learning Managing Archaeological Collections Overview:

<https://www.nps.gov/archeology/collections/index.htm>

University of West Georgia Antonio J. Waring, Jr. Archaeological Laboratory

<https://waring.westga.edu>

#### 3b. National Associations and Accreditation Programs

American Alliance of Museums (formerly American Association of Museums)

<http://www.aam-us.org>

American Association for State and Local History

<http://www.aaslh.org>

#### 3c. Regional Associations

Colorado Wyoming Association of Museums

<http://www.cwam-us.org>

Mountain Plains Museum Association

<https://www.mpma.net>

## Supplies Sources

### 1. Archival boxes, folders, photo storage, etc.:

Archival Methods

[www.archivalmethods.com](http://www.archivalmethods.com)

1-866-877-7050

Gaylord

[www.gaylord.com](http://www.gaylord.com)

1-800-448-6160

Light Impressions

[www.lightimpressionsdirect.com](http://www.lightimpressionsdirect.com)

1-800-656-4876

Talas

[www.talasonline.com](http://www.talasonline.com)

1-212-219-0070

University Products

[www.universityproducts.com](http://www.universityproducts.com)

1-800-628-1912

### 2. Polyethylene bags:

Consolidated Plastics

<https://www.consolidatedplastics.com>

1-800-362-1000

Grainger

[www.grainger.com](http://www.grainger.com)

1-800-grainger

Uline

[www.uline.com](http://www.uline.com)

1-800-295-5510