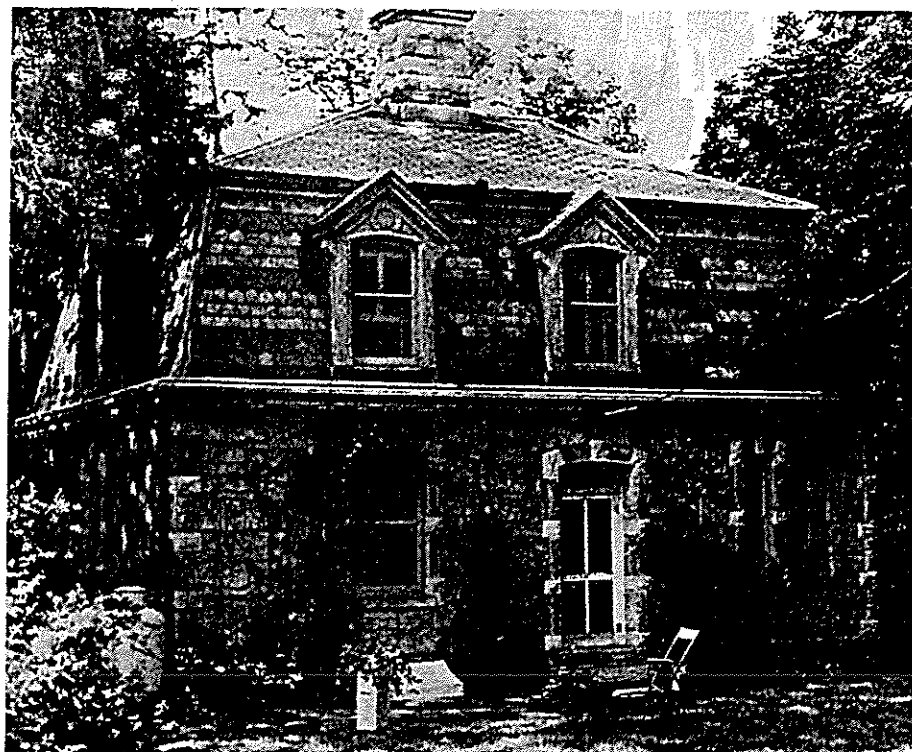

**Tech Notes**

NATIONAL PARK SERVICE  
U.S. DEPARTMENT OF THE INTERIOR  
WASHINGTON, D.C.

**LYNDHURST GATEHOUSE**

Tarrytown, New York

The two-story stone gatehouse on the grounds of the Lyndhurst Estate in Tarrytown, New York, is part of a National Historic Landmark that was once the home of railroad magnate Jay Gould. The property is owned today by the National Trust for Historic Preservation and is open to the public. Built in 1864, the South Gatehouse is used as a private residence for a caretaker.

The windows, with ashlar surrounds on the first floor and decorative wood detailing on the second, are prominent features of the building. The original double-hung wooden windows, with two-over-two pane configuration, have survived in relatively good condition. The 13 windows in the gatehouse are of five different sizes; all but one have an arched head in the upper sash and a thick vertical muntin with a center bead.

The windows on this structure were fitted with custom-made exterior storm windows that meet specified performance criteria and yet minimize both damage and visual obstruction to the historic windows.

**Design Problem**

In many buildings where the historic windows are significant and will be preserved in the rehabilitation project, the installation of storm windows for en-

ergy conservation can require innovative features or some adaptation to standard window designs. This may be necessary in order to minimize damage to historic fabric and to preserve the visual qualities of the historic windows.

Such an approach was taken in the rehabilitation of the South Gatehouse windows at Lyndhurst. As guidance, the following criteria were established beforehand for designing the new storm windows:

1. The new design had to be sympathetic with the historic character of the building.
2. The windows needed to remain operable to allow for ventilation and also for use as possible fire exits.
3. Energy conservation objectives had to be met.
4. Only minimal damage to the historic windows could occur in mounting the storm windows and inconspicuous hardware had to be used.
5. Provisions had to be made for insect screens.

**Design Solution**

A storm window was subsequently developed that meets all of the above requirements. The storm window, in the style of a single casement, was installed on the outside of each of the historic win-

**WINDOWS**

NUMBER 3

**Exterior Storm  
Windows:  
Casement Design  
Wooden Storm Sash**

Wayne Trissler  
National Trust for  
Historic Preservation and  
Charles E. Fisher  
Preservation Assistance Division  
National Park Service

*Physical damage and visual changes to historic windows should be minimized when installing exterior storm windows.*

Figure 1. The single casement, wooden storm window had two removable panels for screen and glass inserts. This custom design fulfilled a variety of requirements established for the project with minimum physical damage and visual changes to the historic windows. Drawing: Martha L. Werenfels

dows and attached to the existing frame (see figure 1). The arched-headed wooden storm window with one-over-one glass panes matched the size of the original double-hung sash. Molding details similar to the original were incorporated in the new storm sash. Each of the two panes in the storm sash was set in thin aluminum frames and secured in the wood storm window with standard clips. This installation technique enables the storm panels to be easily removed by a person on the inside of the house and replaced during the summer with screens (see figure 2).

Mounting hardware consisted of pin-in-socket hinges which required the drilling of only two holes in the existing frame (see figure 3). The hinges allow the window to open casement-style for egress and ventilation purposes.

### Measurement and Fabrication

Each of the window openings was measured and dimensional irregularities identified. The distance from the sill to the bottom of the historic meeting rail was also measured so that a corresponding muntin on the storm sash could be fabricated.

Depending on availability, one inch thick white pine and cypress were selected. Lumber was milled to proper dimensions in the shop facilities on site. The rails and stiles were cut to length with allowances made for the curvature of the window arch.

Figure 2. Section of the wood stile shows how the removable screen and storm panels are secured by use of aluminum clips. Also note that the storm sash was rabbeted along the inside edge to allow retention of original window molding. Drawing: Martha L. Werenfels

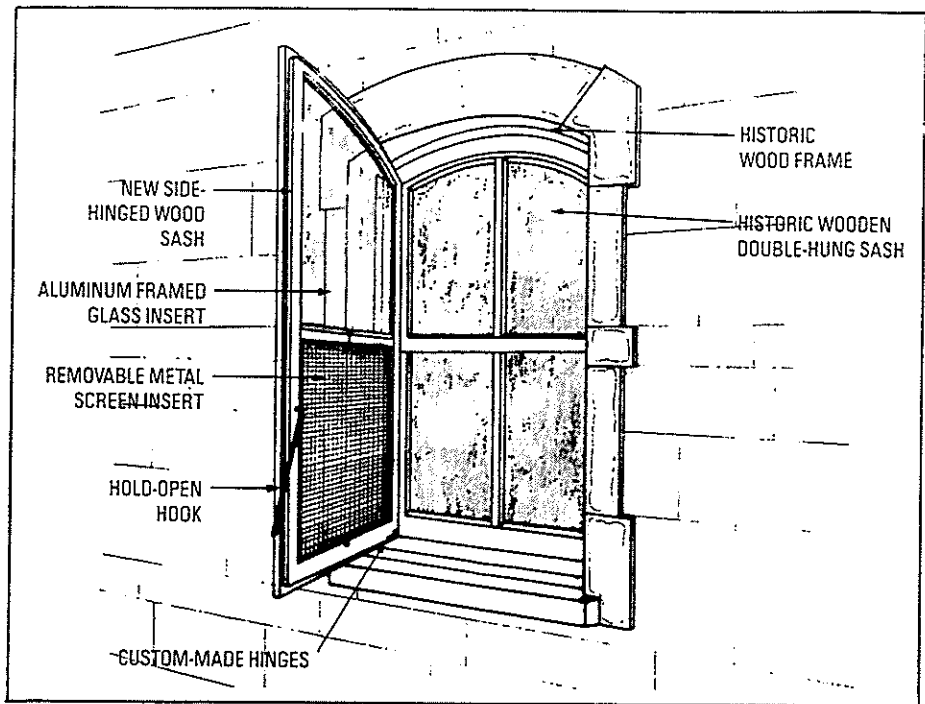
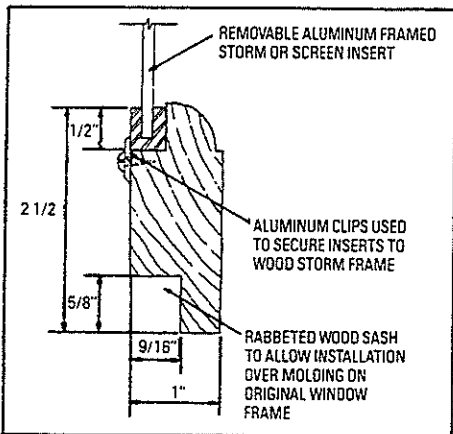

In making arches for the five windows, a template of Masonite was first made for each. By fitting the template to the historic arch, it was then possible to trace the top of each on a piece of 5 1/2" wide pine or cypress to make the top rails for each window.

Dowels were used to join the rails and stiles. Two holes for 3/8" by 2" dowels were drilled for each joint with the exception of the top rail. For the arch, only one hole per joint was made due to the lack of space.

Before the windows were fitted together, the inner moldings on the rails and stiles were cut on the shaper to match the 9/16" quarter mound molding on the historic sash.

### Assembly

In fitting the windows together, the parts were glued at the joints with resorcinol glue, dowels inserted, and the clamps attached while the glue hardened overnight (see figure 4). After the joinery was completed, the tops of the stiles were cut to fit the curvature of the arch. For the first floor windows, a 5/8" by 9/16"

Figure 3. The only feature of the storm window that required expensive custom work was the pin-in-socket hinges (bottom one shown in photograph). Commercially available hardware could have been used; however this project sought to minimize physical damage to historic woodwork and thus tested a prototype design. Stainless steel was used for reduced maintenance costs. Photo: Richard Bierce, AIA

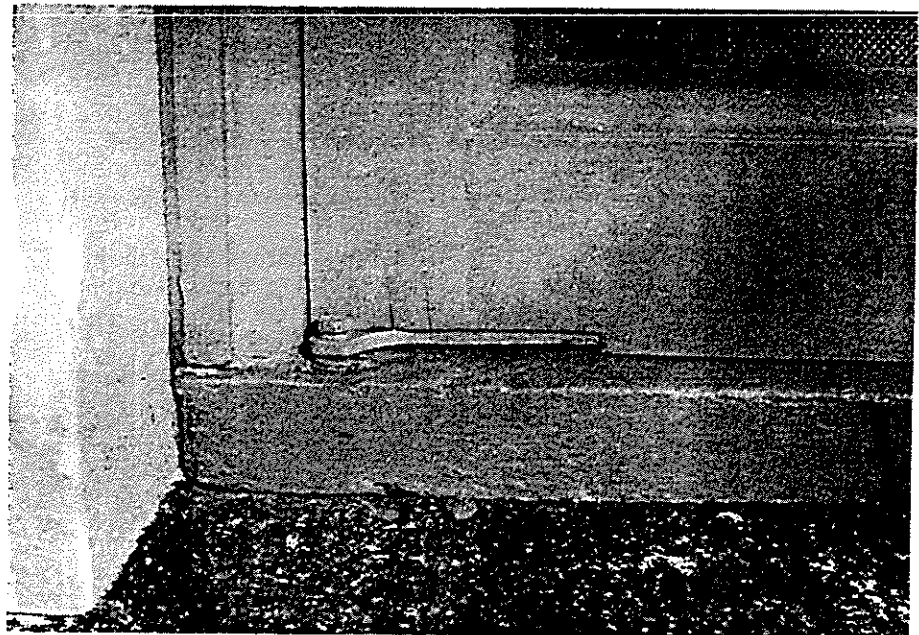

rabbet was cut along the outer edge to allow the window to fit over the existing moldings on the historic window frame.

The windows were then fitted to each opening and bottoms planed to a slight angle corresponding to the sill. Two weep holes were cut in the bottom to allow condensation to escape, and the windows were permanently labeled as to their location in the building.

Custom-made stainless steel hinges of a pin-in-socket design were attached to the left side, top and bottom, of each window. The windows were then sanded, treated with a non-toxic preservative, and primed with an oil-alkyd paint.

### Inserts

The two aluminum-frame storm inserts for each window were constructed of moldings cut on a mitre. The top pane of glass was cut to follow the arch of the top rail, and the units were then assembled and labeled. Screens were cut and assembled in a similar manner. The aluminum frames were roughened with sandpaper, and painted with two finish coats. After the paint had thoroughly dried, the storm inserts were installed with small aluminum hold-downs on the inside of each window.

### Final Installation

In hanging the windows,  $\frac{3}{4}$ " holes were drilled in the sill and the top of the historic window frame to accommodate the stainless steel anchor. The holes were thoroughly soaked with the same

wood preservative used on the sash, then filled with a polysulfide caulk before the anchor was inserted. After the windows were installed, 1 inch hook-eyes were attached to secure the windows shut while a second hook-eye, 1 foot long, was installed on each window to hold it in a fixed position when opened (see figure 5).

wood preservative used on the sash, then filled with a polysulfide caulk before the anchor was inserted. After the windows were installed, 1 inch hook-eyes were attached to secure the windows shut while a second hook-eye, 1 foot long, was installed on each window to hold it in a fixed position when opened (see figure 5).

### Project Evaluation

The storm window used on the gatehouse incorporates several desirable design features. It is a successful preservation solution by maintaining the arched head of the windows; proportioning the framing members along the basic lines of the primary sash; matching the materials of the historic window and avoiding damage to historic fabric. The casement design does not impede use of the windows for emergency egress, and the panel inserts set on the inside of the storm frame provide for convenient seasonal change from storm to screen units without relying on obtrusive multiple-jamb tracks. While the custom hardware is perhaps a luxury feature, for economy purposes standard hardware could have been substituted. The storm windows, moreover, are detailed so that almost any local mill could easily make them. This sensitive storm window design has widespread applicability to many other historic buildings where owners are seeking to maintain and upgrade the existing historic windows in an aesthetically pleasing and practical manner.

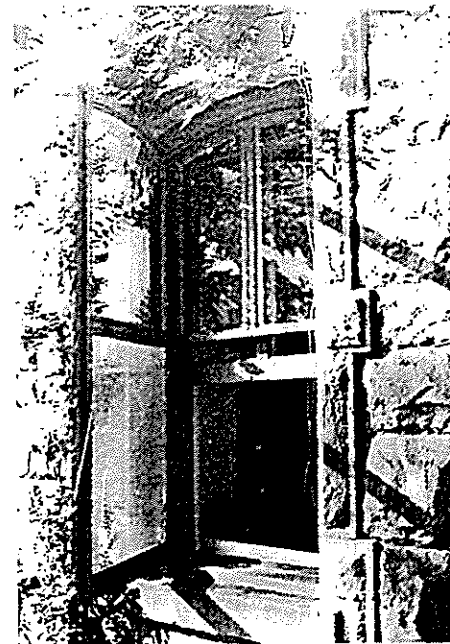

Figure 5. The new wooden storm sash was installed in the historic frame; the edge of the storm frame was rabbeted to accommodate the historic molding on the old wood frame. Photo: Richard Bierce, AIA

### PROJECT DATA

#### Building:

South Gatehouse  
Lyndhurst Estate  
National Trust for Historic Preservation  
635 South Broadway  
Tarrytown, New York

**Project Date:** January-March, 1980

#### Project Staff:

Wayne Trissler, Apprentice,  
and Joseph Lewes, Master  
Restorationist  
National Trust Restoration Workshop  
635 South Broadway  
Tarrytown, New York

#### Materials:

Stainless Steel Hardware-  
Wesco F. G. Corporation  
Bridge Street  
Box 3  
Irvington, New York

#### Project Costs:

The fabrication of the windows was undertaken by an apprentice at the National Trust Restoration Workshop at Lyndhurst. No cost figures are available.

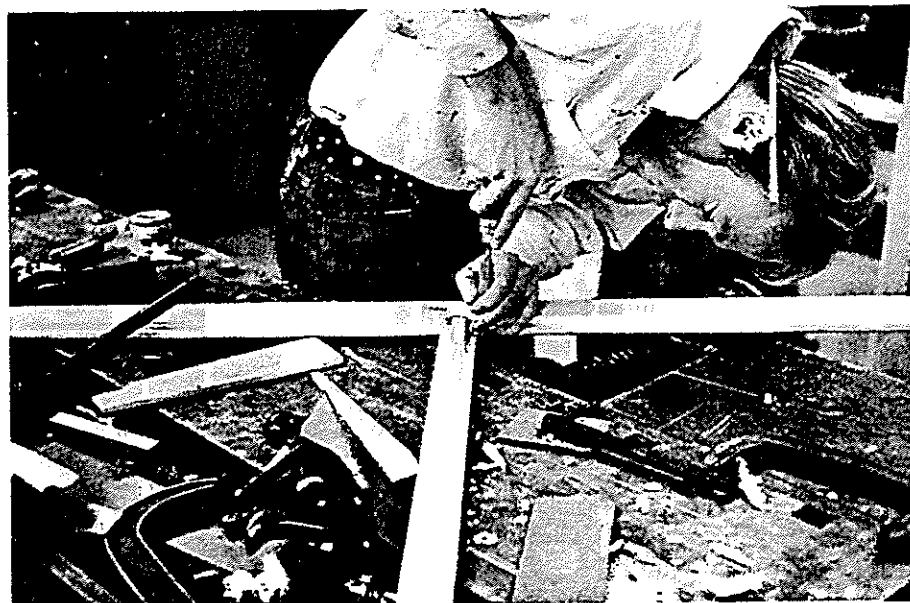

This PRESERVATION TECH NOTE was prepared by the National Park Service in cooperation with the Center for Architectural Conservation, Georgia Institute of Technology. Charles E. Fisher, Preservation Assistance Division, National Park Service, serves as Technical Coordinator for the TECH NOTES. Special thanks go to Alan Keiser, Director of the National Trust Restoration Workshop for his time and assistance in providing information concerning the window work on the gatehouse. Thanks also go to the following people who contributed to the production of this TECH NOTE: John H. Myers and Laura A. Muckenfuss, Center for Architectural Conservation, and Preservation Assistance Division staff, particularly Kay D. Weeks, Martha L. Werenfels, Mae Simon, Michael J. Auer, and Martha A. Gutrick. Cover, Gatehouse Photo: Courtesy, National Trust for Historic Preservation.

This and many of the TECH NOTES on windows are included in "The Window Handbook: Successful Strategies for Rehabilitating Windows in Historic Buildings" (available late 1984), a joint publication of the Preservation Assistance Division, National Park Service and the Center for Architectural Conservation, Georgia Institute of Technology. For information, write to The Center for Architectural Conservation, P.O. Box 93402, Atlanta, Georgia 30377.

PRESERVATION TECH NOTES are designed to provide practical information on innovative techniques and practices for successfully maintaining and preserving cultural resources. All techniques and practices described herein conform to established National Park Service policies, procedures, and standards. This TECH NOTE was prepared pursuant to the National Historic Preservation Act Amendments of 1980 which directs the Secretary of the Interior to develop and make available to government agencies and individuals information concerning professional methods and techniques for the preservation of historic properties.

Comments on the usefulness of this information are welcomed and should be addressed to TECH NOTES, Preservation Assistance Division, National Park Service, Washington, D.C. 20240. This publication is not copyrighted and can be reproduced without penalty. Normal procedures for credit to the authors and the National Park Service are appreciated.

ISSN: 0741-9023

PTN-3

January 1984