



## COLONIAL WILLIAMSBURG

Williamsburg, Virginia

The Williamsburg National Historic Landmark District consists of approximately 500 buildings that have been restored or reconstructed to their 18th century appearance. A vast majority of the buildings are owned by The Colonial Williamsburg Foundation; many opened to the general public as part of an educational program.

Twenty-three of the non-exhibition buildings, most of which are used for rental housing, were selected for retrofitting storm windows as part of Colonial Williamsburg's ongoing energy conservation program. A simple commercially available interior storm window system was chosen and certain modifications were made for aesthetic and functional reasons.

### Rehabilitation Design Problem

In improving the energy performance of windows in historic buildings, installing a system of double glazing is usually one of the first considerations in areas with long heating seasons. Installation options may include adding a traditional exterior or an interior storm window; routing out the frame of the historic sash to insert a double-glazed thermal unit; or under certain conditions, replacing the deteriorated historic sash with a new double-glazed one that preserves the historic character of the window.

In assessing these options, it is understandable that the initial cost of

installation will be a major consideration, but it should not be the controlling factor. In working with historic buildings, emphasis should be placed on not only maintaining the historic appearance but also preserving as much of the historic building material as possible. In addition, there are often special considerations based on the use of the historic building, as in the case of those owned and operated by The Colonial Williamsburg Foundation.

When Colonial Williamsburg began an accelerated program of energy conservation for their many historic and reconstructed buildings, they surveyed those buildings not open to the public to ascertain the possibility of improving thermal performance and reducing the air infiltration of the windows. Since nearly 40% of the windows in the historic buildings are all or in part original, the decision was made to examine the possible use of storm windows. To minimize the visual and physical alterations to the windows, especially as viewed from the outside, an interior storm window system was considered the best approach. Since half-screens had previously been installed on the inside of most of the buildings, and these were still in good condition, new screen units were not required.

The following design criteria were thus established for the interior storm window systems:

1. The storm window had to be

## PRESERVATION

# Tech Notes

NATIONAL PARK SERVICE  
U.S. DEPARTMENT OF THE INTERIOR  
WASHINGTON, D.C.

## WINDOWS

NUMBER 9

### Interior Storm Windows: Magnetic Seal

Charles E. Fisher  
Preservation Assistance Division  
National Park Service

*Physical damage and visual changes to historic windows should be minimized when installing storm windows.*

largely invisible to the general public as viewed from the outside.

2. No mechanical fasteners could be used that would damage the historic woodwork.

3. The storm window needed to be removable or self-storing to allow natural ventilation during the summer months.

4. Installation had to be achieved with minimum inconvenience to the tenants.

5. Air infiltration needed to be appreciably reduced both for energy reasons and for improved personal comfort of the tenants.

6. The storm units needed to accommodate the irregularities of the historic windows and also the varied assortment of draperies, blinds and window trim.

7. As viewed from the interior, the storm windows had to be as unobtrusive as possible.

8. A reasonable payback period for the windows through improved energy performance was required.

## Rehabilitation Design Solution

The interior storm window system selected by Colonial Williamsburg consisted of a clear acrylic sheet in a polymer frame that contained a flexible magnet on the back side. When the storm window was set against an adhesive-backed steel strip pre-attached to the historic interior window trim, a magnetic seal was formed (see figure 1). The advantages to this design solution were the ease of installation without any damage to the original woodwork or sash, and the small visual impact it had on the exterior appearance of the window.

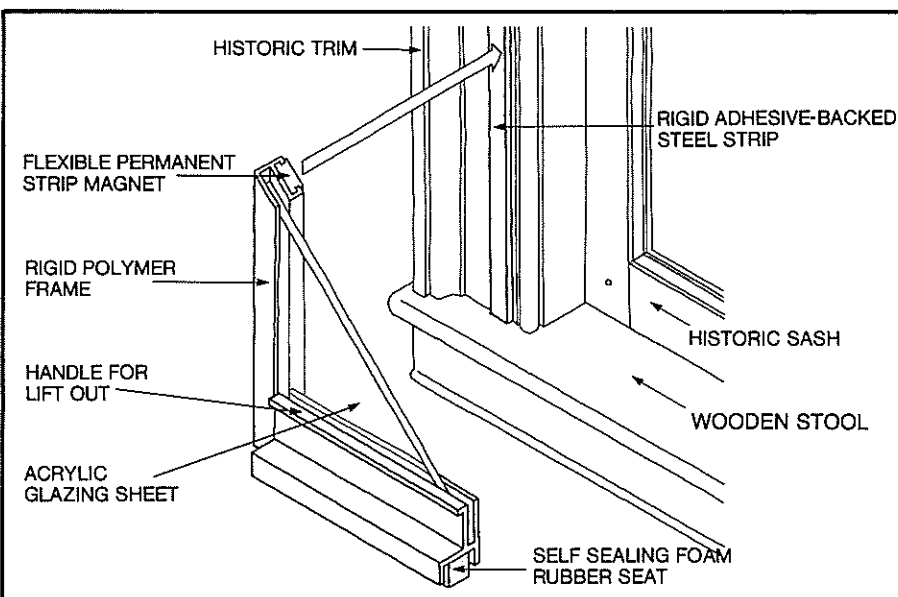

Figure 1. The interior storm window system chosen consisted of a clear acrylic glazing sheet set into a polymer frame that adhered to the existing window trim through use of a magnetic seal. Drawing: Christina Henry.

Two potential drawbacks of this and other types of interior storm windows were recognized from the beginning.

First, the addition of the interior storm window could result at times in a slight shadow effect created by the wooden muntins of the original sash reflecting off the storm glazing. The other potential problem was that condensation could be trapped between the original sash and the storm unit. In the past, condensation had occurred during winter months, particularly on the north facades where high air infiltration due to prevailing winds was common, and also in rooms with high humidity, such as bathrooms and kitchens. With the new storm windows in place, it was assumed that there would be fewer condensation problems. If moisture runoff from condensation did occasionally collect on the sills of individual windows, it could be wiped off. Based on the results from the test buildings, however, condensation has not been a problem to date. Building conditions, use, and climatic differences might lead to different results, however, on other projects.

## Single-Unit Storm Window

Two different storm window designs, single unit and split unit, were utilized in order to accommodate the varying window sizes and operability requirements. The least expensive design was the single-unit storm window covering the entire window opening and used in buildings with year-round climatic controls in which operable windows were unnecessary.

There are size limitations for the use of the single unit. For example, had the

windows been as large as 4 by 8 feet or particularly long and narrow, a split unit would have been required to avoid potential problems from thermal expansion. Other allowances, for expansion and contraction would also have been necessary had any of the storm units been set within the jamb rather than surface-mounted. In the case of the buildings at Colonial Williamsburg, the window sizes were such that any thermal expansion, according to the contractor, would only result in the storm window slightly "creeping" along the steel strips with the magnetic seal not breaking.

Most of the historic windows at Colonial Williamsburg had been trimmed with a stool so that a magnetic seal was obtained only on three sides of the polymer frame (see figure 2). A small metal angle frame or wood stop could have been added to the stool to permit a magnetic seal on the fourth side but such alterations were avoided.

Figure 2. The thin-framed storm unit is shown attached by a magnetic seal to the existing trim. The protective film on the acrylic will later be removed. Photo: Tom H. Taylor.



A slightly different polymer frame configuration was used for the bottom of the storm window in cases where a window stool existed. The sill framing was attached to the acrylic sheet like the typical polymer frame, with the exception that the bottom was extruded with a 1/4" U-channel that had a latex gasket glued in place to form a tight seal (see figure 1).

## Split-Unit Storm Window

The storm window design most commonly used at Colonial Williamsburg consisted of a separate upper and lower part with an interconnecting meeting bar. This style was used in windows where the original double-hung sash needed to remain operable. A split-unit interior storm window has an advantage over a single unit in that it did not need to be removed and stored in the summer months. By attaching the lower unit to the upper unit via a magnetic seal, the storm window could be left in place, thereby avoiding problems of storage and reducing the chances of the acrylic sheets being scratched or warped (see figure 3).

Figure 3. Vertical section showing a split unit in place and the option of piggybacking the lower unit onto the upper for storage during the summer. See figure 6 for detail on the manner of attaching the piggybacked unit. Drawing: Christina Henry.

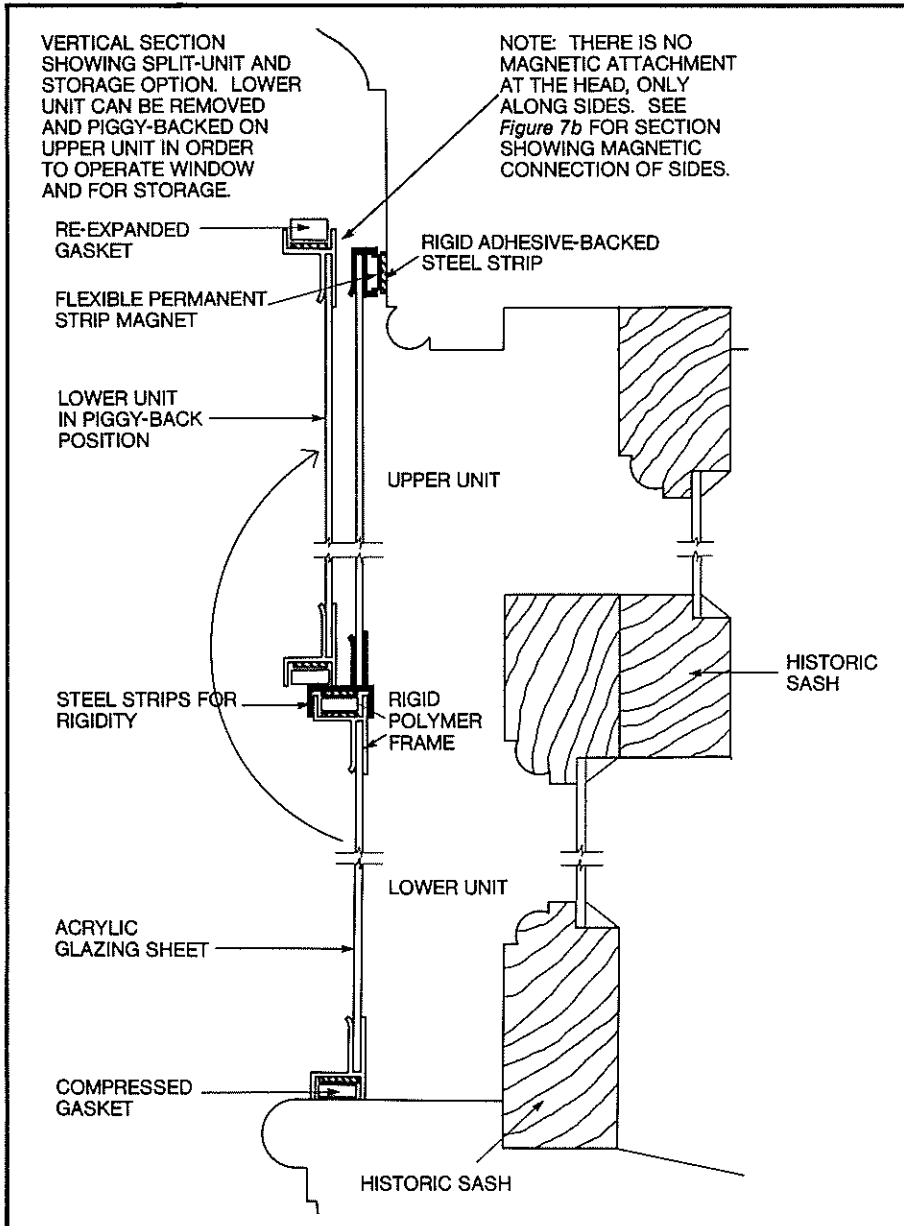

The design of the split units met two important considerations: (1) the meeting bar of the interconnecting units could be located so as to have minimal visual impact from the exterior, and (2) a sound connection between the split units was created. To accomplish the latter, the standard 1/4" U-channel with a latex gasket used on the stool framing was, in turn, used on the upper horizontal edge of the lower window unit (see figure 3). On the lower horizontal edge of the upper window unit, a slightly larger U-channel was incorporated into the bottom of the polymer frame to fit snugly over the upper facing U-channel and gasket used on the top of the lower unit (see figure 4). This feature thus served to diminish air infiltration and also provided additional reinforcing along the midsection of the complete storm unit.

The placement of this meeting bar primarily depended on its visual impact on the outside. Where the historic upper and lower sash were the same size, the meeting bar of the interior storm was lined up as closely as possible behind the meeting rail of the historic sash (see figure 5). In a number of windows, however, the pane configuration made it harder to disguise the appearance of the interior storm meeting bar from the outside. These windows had 6 panes over 9, the bottom sash being considerably larger. In such cases, it was specified that the bottom of the top storm unit would stop at the first horizontal muntin below the meeting rail on the historic sash.

Figure 4. This view shows only the upper unit in place. The U-channel along the bottom of this unit was designed to fit over a similar U-channel at the top of the lower unit. With the lower unit removed in summer as shown, only the adhesive-backed steel strip is visible. Photo: Tom H. Taylor.

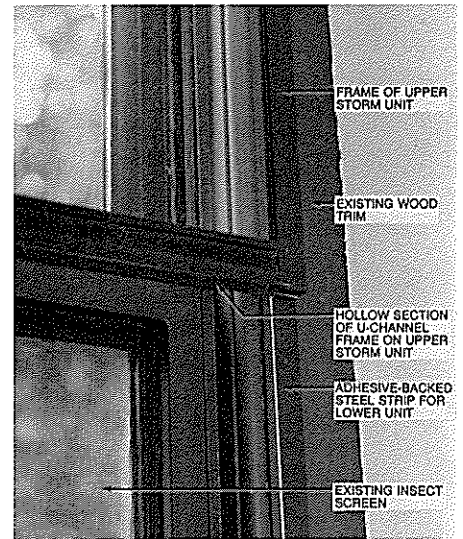
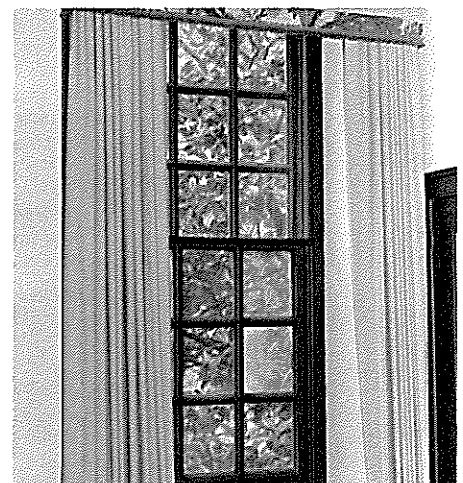

Figure 5. The meeting bar of the split storm unit shown in place was located adjacent to the historic meeting rail in windows where the upper and lower sash were the same size. Photo: Tom H. Taylor.



## Self-Storing Feature of the Split-Unit Window

To allow for the storage of the lower unit, an adhesive-backed steel strip was attached to the face of the vertical polymer frame on the upper unit. Thus the two vertical framing members in the upper unit had a magnet on one side and a steel strip on the other. The addition of the metal strip allowed the lower unit to be magnetically attached to the steel on the upper unit when in a storage position (see figure 6).

To keep the upper unit from creeping downward due to the additional weight of the piggybacked lower storm, a  $\frac{3}{8}$ " shelf with a  $\frac{3}{16}$ " upward turn was formed in the two wood-adhering vertical steel strips at a point aligning with the bottom of the upper unit (see figure 7).

A similar feature was added at the bottom of both single and split units when no stool existed in the historic window. To deter possible creeping and, as a safety measure, the bottom of the vertical steel strip was turned 90 degrees outward to act as a small shelf for the storm window. A small plastic tip was attached to the sharp edge of this shelf to protect draperies.

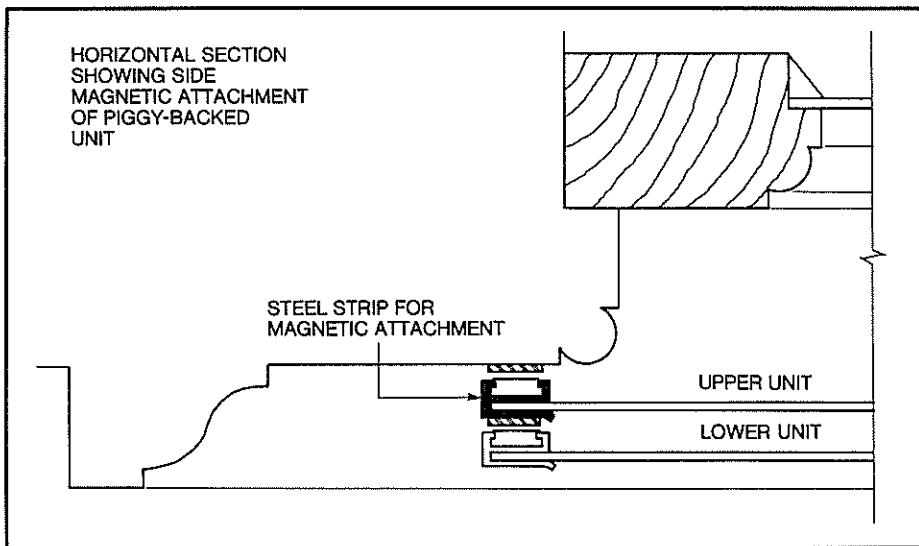
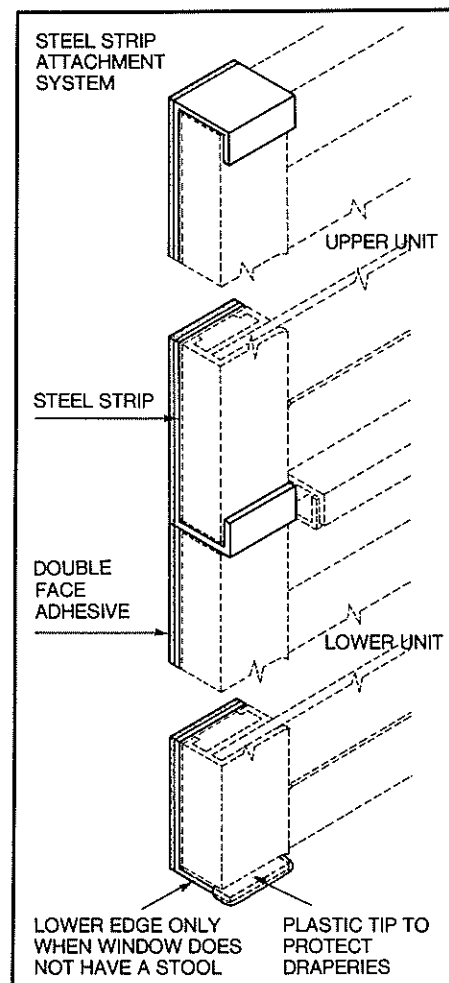

Figure 6. Horizontal section of the upper storm unit shows how with an additional adhesive backed steel strip added to the sides of the upper storm frame it was possible to piggyback the lower storm unit for storage purposes during the summer.

Drawing: Christina Henry.

Figure 7. (a) In cases where there were no stools and also where a split unit was used to facilitate self-storage, small "shelves" were made in the vertical steel strips to deter creeping. Photograph shows a 90 degree angle at the bottom of the vertical steel strip in a situation where there was no stool. Photo: Tom H. Taylor. (b) The adjacent drawing shows the two "shelves" used with split units as well as a top safety catch formed at the end of the steel strip.

Drawing: Christina Henry.



## Fabrication and Installation

For the convenience of the contractor and the residents of each building, it was decided not to fabricate the windows at the job site. Working on one building at a time, the contractor measured each window, cut the acrylic sheets, and attached the polymer frames at the shop. Where the historic windows were skewed — some having lost their rectangularity due to settling — the storm units were cut oversize at the shop to allow for custom fitting at the site. The protective masking on the acrylic was left in place until final installation in order to reduce the chances of scratching. It was necessary, however, to roll the masking back from the edges when attaching the polymer frames.

Prior to shipment to the site, the adhesive-backed steel strips, which were to be mounted to the wooden window trim, were cut and temporarily affixed to the bar magnet set in the polymer frame; the pull-off tape was left on. Affixing the adhesive steel strip to the bar magnet greatly facilitated proper alignment onto the existing wooden window during the final installation.

After removing the blinds and draperies, the prefabricated storm window was held up to the historic window and checked for any necessary adjustments. For windows that were skewed, the polymer frames and the acrylic glazing were easily cut onsite for a correct fit. When ready for installation, the masking tape was removed from the adhesive side of the steel strip and, with the steel strip still attached to the polymer frame (via the magnet), the window was aligned and pressed firmly against the wooden trim. In this way, the steel strip adhered to the wooden trim while maintaining a correct alignment with the magnet in the polymer frame. In some cases, due to irregularities in the surface of the wooden trim, it was necessary to build up behind the steel strips using double faced tape to accommodate gaps as much as  $\frac{1}{8}$ ". The storm window was then checked for ease of removal and the protective masking removed from the acrylic. Two workers were able to install about 25 windows in an average working day.

## Post-Installation Evaluation

The unobtrusive nature of these storm windows is an advantageous feature, along with the fact that no physical damage or alteration to the original window is required (*see figure 8*).

Building tenants have noticed a major increase in personal comfort during the winter months, especially while sitting near the windows, and have experienced a substantial reduction in outside noise. Specific energy savings have not been calculated, but tenants report significant energy savings during the first winter.

It is anticipated that the acrylic glazing will be scratched over the long term, especially since some of the tenants have elected to store the lower storm units elsewhere during the sum-

mer rather than piggyback them. Colonial Williamsburg gives its tenants specific cleaning instructions including information on available products to remove minor marks.

There are available for the split units separate screens which can be installed in the bottom half and removed during winter months. These were not used at Colonial Williamsburg because of interior half screens already existing within the jamb.

These single-and split-unit storm windows have been successfully used in both commercial and residential rehabilitation projects in other states. By minimizing physical damage and changes in the visual qualities of the historic window, this interior storm window has provided two features desirable for other historic buildings.

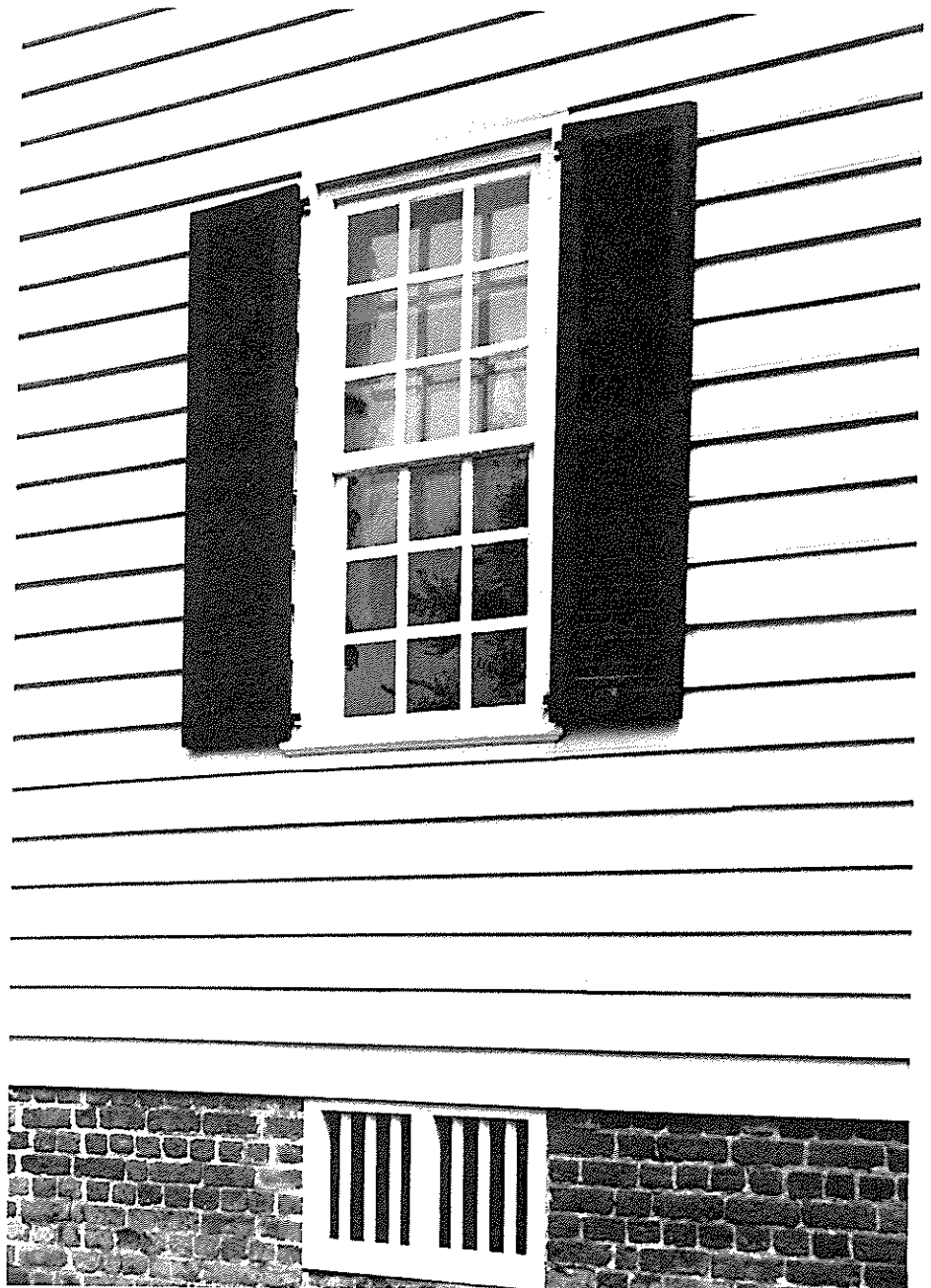

Figure 8. The unobtrusive interior storm window required no physical damage or exterior visual alteration to the original window. Photo: Tom H. Taylor.

## PROJECT DATA

**Building:** 23 buildings

Owned by The Colonial  
Williamsburg Foundation,  
Williamsburg, Virginia

**Project Date:** 1982-1983

## Project Staff:

Tom Taylor, Jr., Chief, Architectural  
Conservator  
Bill Black, Project Architect  
Paul Hurley, Superintendent, Building  
Maintenance Department,  
The Colonial Williamsburg Foundation  
P.O. Box C  
Williamsburg, Virginia

Sam Massey, Jr., Window Consultant  
and Contractor  
Vencon, Inc.,  
P.O. Box 210  
Shacklefords, Virginia

## Materials:

Magnetrim Window—  
Energy Options of Virginia, Inc.  
8439 Glazebrook Avenue  
Richmond, Virginia

Magnetite Window—  
Viking Energy System Co.  
275 Circuit Street  
Hanover, Massachusetts

## Project Costs:

Manufacture and installation of 461  
interior storm windows (7,410 square  
feet) on 23 buildings—\$34,124 (\$5.28  
square foot).

This PRESERVATION TECH NOTE was prepared by the National Park Service in cooperation with the Center for Architectural Conservation, Georgia Institute of Technology; funding assistance was provided by the Office of Solar Heat Technologies, Conservation and Renewable Energy, U.S. Department of Energy. Charles E. Fisher, Preservation Assistance Division, National Park Service, serves as Technical Coordinator for the PRESERVATION TECH NOTES. Information on the interior storm window installation work at Colonial Williamsburg was generously supplied by Sam Massey, Jr., who served as the window contractor; by Nicholas A. Pappas, FAIA, Foundation Architect, and Tom H. Taylor, Jr., Chief, Architectural Conservator, The Colonial Williamsburg Foundation. Special thanks go to Kay D. Weeks, Preservation Assistance Division, National Park Service, for her help in writing this Tech Note. Thanks also go to the following people who contributed to the production: John H. Myers, Center for Architectural Conservation, and Preservation Assistance Division staff, particularly Michael J. Auer, Christina Henry, Brenda Johnson, Martha L. Werenfels, Martha A. Gutrick, and Mae Simon. Cover Photo: Tom H. Taylor.

PRESERVATION TECH NOTES are designed to provide practical information on innovative techniques and practices for successfully maintaining and preserving cultural resources. All techniques and practices described herein conform to established National Park Service policies, procedures, and standards. This Tech Note was prepared pursuant to the National Historic Preservation Act Amendments of 1980 which directs the Secretary of the Interior to develop and make available to government agencies and individuals information concerning professional methods and techniques for the preservation of historic properties.

Comments on the usefulness of this information are welcomed and should be addressed to PRESERVATION TECH NOTES, Preservation Assistance Division, National Park Service, Washington, D.C. 20240. This publication is not copyrighted and can be reproduced without penalty. Normal procedures for credit to the authors and the National Park Service are appreciated.

ISSN: 0741-9023

PTN-9

September 1984

This and many of the PRESERVATION TECH NOTES on windows are included in "The Window Handbook: Successful Strategies for Rehabilitating Windows in Historic Buildings" (available late 1984), a joint publication of the Preservation Assistance Division, National Park Service and the Center for Architectural Conservation, Georgia Institute of Technology. For information write to The Center for Architectural Conservation, P.O. Box 93402, Atlanta, Georgia 30377.